

## RESEARCH ARTICLE

# A Criterion for Designing Emergency Control Schemes to Counteract Communication Failures in Wide-Area Damping Control

MOKHTAR BENASLA<sup>1</sup>, FELIX RAFAEL SEGUNDO SEVILLA<sup>2</sup>, (Senior Member, IEEE),  
PETR KORBA<sup>2</sup>, (Senior Member, IEEE), TAYEB ALLAOUI<sup>1</sup>, AND MOULOUD DENAI<sup>3</sup>

<sup>1</sup>L2GEGI Laboratory, Electrical Engineering Department, Ibn Khaldoun University, Tiaret 14000, Algeria

<sup>2</sup>Institute of Energy and Fluid Engineering, Zurich University of Applied Sciences, 8401 Winterthur, Switzerland

<sup>3</sup>School of Engineering and Technology, Hertfordshire University, AL10 9AB Hertfordshire, U.K.

Corresponding author: Felix Rafael Segundo Sevilla (felixrafael.segundosevilla@zhaw.ch)

**ABSTRACT** Communication failures and transmission delays are two major issues associated with Wide-Area Damping Controllers (WADCs). While transmission delays have been extensively studied and various solutions have been proposed, little research has been done on communication failures and most of the proposed methods are based on preventive controls. However, in today's liberalized electricity markets, preventive controls are no longer acceptable and the trend is to use emergency controls instead. This paper proposes a novel emergency control scheme to counteract the loss of remote signals related to the input and to the output of the WADC (i.e. sensor and actuator failures). The proposed scheme is based on a simple criterion, which overcomes the complexity of the previous methods. Modal analysis and time domain simulations are performed to verify the performance of the proposed method. The simulation results show that the proposed method performs well in handling communication failures and can maintain good damping performance. This research work is particularly important in view of the trend towards the wide-scale adoption of wide-area measurement technologies, while the vulnerability to cyber-attacks is increasing.

**INDEX TERMS** Communication failures, emergency control, inter-area oscillations, wide-area damping controller (WADC).

## I. INTRODUCTION

With the increasing demand for energy globally over the past decades and the expansion of modern interconnected powers system such as the ENTSO-E network in Europe, inter-area low-frequency oscillations are becoming one of the major threats to the security and reliability of large power systems. In many cases, unacceptable inter-area oscillations have become the power-transfer limiting factor of interconnected grids [1]. In addition, if not well-damped, these oscillations may pose a serious threat to system security after some contingencies, such as line tripping [1], [2], [3]. Power System Stabilizers (PSS) have long been considered an effective way to dampen low frequency oscillations in power systems. However, over the years, the traditional PSS was found not

to be effective in damping inter-area modes under certain situations. These controllers are generally based on local input signals and the inter-area modes may be controllable from one area and observable from another [4]. PSSs based on remote signals called WADC (Wide-Area Damping Controller) have been proposed to overcome this limitation of conventional PSSs. WAMS (Wide Area Measurement Systems) based on PMUs (Phasor Measurement Units) have experienced a rapid development in recent years and the technology has already been deployed in several power systems around the world. WAMS offer the possibility of designing and applying WADC to get best performance in damping inter-area oscillations [5]. Several approaches for the design of WADC have been proposed in the literature [6], [7], [8], [9], [10], [11]. However, there are two important practical challenges associated with the use of WADC: transmission delay and communication failure. The problem of transmission time

The associate editor coordinating the review of this manuscript and approving it for publication was Siqi Bu<sup>1</sup>.

delay has been extensively addressed in the literature [12], [13], [14], [15], [16], [17]. However, research on communication failures has been very limited and the major contributions addressing this concern can be found in [18], [19], [20], [21], [22], [23], [24], [25], [26], [27], and [28]. With the expected increase in the adoption of WADCs in the future and the use of WAMS technology, power systems will be more susceptible to information failures and malicious attacks, such as cyber-attacks [1]. Therefore, it is very important to design effective control techniques to enhance the resilience of the system against communication failures.

Potential failures in the communication links of the WADC have been addressed in a few studies and some solutions have been proposed. Among these, FTC (Fault-Tolerant Control) was found very effective [29], [30], [31]. FTC can be classified as either active or passive. In passive schemes, the fault tolerance is achieved by designing the controller to cope with future faults (given by a set of possible failures) without any additional post-fault control. In active schemes, the control action is triggered only if the predefined failure occurs, i.e. it acts in the post-fault state. Thus, passive and active controls in FTC theory can be seen as the usual preventive and emergency controls employed in power systems security control. Although passive schemes are simple to implement, the design of such controllers is a complex task and requires more sophisticated control techniques [28]. Furthermore, passive schemes work in a preventive manner, which means that they are conservative in action during normal system conditions. Several techniques have been presented to provide control resiliency against communication failures in a preventive way [18], [19], [20], [21], [22], [23], [24]. In such a case, the WADC is designed to ensure satisfactory damping performance for the defined possible communication failures. This technique is effective and leads to a robust WADC against communication failures. However, it generally faces a trade-off between security and economics as it requires large backup reserves. This is being seen as a barrier to competition in open electricity markets where power systems are operated closer to their stability limits. This creates strong incentives to rely less on preventive control and more on emergency control. However, because of the complexity and high costs, emergency control schemes are rarely adopted. Most utilities around the world still rely on preventive control techniques to maintain the security of their systems and emergency control schemes are only used as an additional line of defense. Since communication failures occur rarely, emergency control is therefore ideal for this type of event, which makes it possible to minimize the reserves required as it acts only in the post-contingency state.

Generation re-dispatch is the most addressed emergency control in the literature to counteract inter-area oscillations [32], [33], [34], [35]. Load shedding has also been addressed in some studies [36]. These techniques incur considerable cost and their implementation in modern power systems is a complex task. However, when the oscillation problem is

associated with a WADC failure, it is possible to design other emergency controls and avoid the costly techniques. To the best of our knowledge, little work has been done in this area, focusing mainly on actuator failure [25], [26], [27], [28]. The concept of “virtual actuator” has been used to design active FTC to handle actuator failures. When an actuator failure occurs, the control signal is redirected to other available actuators using the redundancy concept (i.e. redundant actuators). However, to redirect the WADC control signal to other available actuators, an automatic approach is required to redesign the nominal WADC, which is a complex task. To overcome this problem, a reconfiguration block (virtual actuator) has been widely used to re-route the control signal without the need to redesign the nominal WADC [26], [27]. The reconfiguration block is installed between the nominal WADC and the new actuator which is triggered only when an actuator failure occurs. This approach is effective, but it requires several reconfiguration control blocks to increase reliability of the system as a reconfiguration block is required for each actuator. This increases the complexity and the size of the controller as in [26] where the reconfiguration blocks appear as a bank of virtual actuators. Unlike actuator failure which can be handled by the virtual actuator concept, it is more complicated to handle sensor failures using active FCT schemes. The inevitable solution is to switch a new WADC considering redundant communication signals. This solution is proposed in [25] where several controllers have been used, each corresponding to a measured signal (i.e. feedback signal). This solution is not practical since multiple controllers are required for each nominal WADC [19], [23].

Clearly, any emergency control dealing with sensor or actuator failures will alter the wide-area control loop. In case of actuator failure, a new actuator is used, while in case of sensor failure, a new feedback signal is used. Generally, every control loop not only has an impact on the concerned mode but also influences other oscillation modes. This interaction issue can be a serious concern if not handled properly. Usually, the nominal control loop is chosen carefully in the design stage of the WADC. This would result in a large effect on the concerned mode, without affecting the other modes hence reducing the interactions among different modes. Therefore, when the nominal control loop changes during any emergency control action, the interaction problem should be considered. However, taking the interaction problem into account when designing emergency control schemes will greatly increase the complexity of the design and reduce the possibilities of finding suitable actuators/feedback signals. For this reason, the interaction problem has not been considered in the proposed emergency control schemes available in the literature, which is a major drawback. Thus, it is very important to find an acceptable solution to overcome this drawback and design effective emergency control schemes.

To overcome most of the mentioned drawbacks of previously proposed emergency control schemes, this paper proposes a novel emergency control scheme to counteract

communication failures in WADC. The main contributions of this paper are summarized as follows:

- A novel emergency control scheme based on a simple criterion is proposed to efficiently counteract the failure of WADCs. The approach can handle both sensor and actuator failures. For actuator failure, this paper extends [26], [27] in which the nominal actuator can be replaced with other available actuators without the need to reconfigure the WADC or add a reconfiguration scheme. For sensor failure, this paper extends [25] in which the faulty feedback signal can be replaced with a healthy signal without the need for another controller. Based on the proposed criterion, our control scheme can handle the case where sensor and actuator failures occur simultaneously.
- An effective solution is presented to lessen the difficulty of dealing with the interaction problem when designing emergency control schemes. The emergency control can be designed without considering the interaction problem, then the interaction effects with other modes can be alleviated by installing a finely tuned filter.
- The proposed method is simple to implement, from a computational point of view and from the point of view of the necessary skills of system operators.

The remaining of the paper is organized as follows. Section II describes the relation between the application of WADC and the N-1 criterion. Section III presents the structure of WADC and discusses the possible failures. Section IV reviews the residue method and its application to PSS design. In Section V, the proposed emergency control scheme is presented. The simulation results to assess the performance of the proposed control are presented in Section VI. Finally, the conclusions of the paper are summarized in Section VII.

## II. WADC AND THE SECURITY CRITERION

As discussed above, in today's power systems, there are several situations where stability limits of the inter-area oscillations are reached before the traditional limits such as thermal limit. Wide-area control is inherently more effective than local control for damping inter-area oscillations. However, compliance with security criteria could affect the benefits obtained by the installation of WADCs. To explain this clearly, the simple example shown in Fig. 1 is considered. In this system, Areas A and B are connected through three transmission lines, which are identical and have a capacity of 200 MW each. The power transfer is assumed to be limited by a critical inter-area mode between the two areas. A load of 1000 MW is connected to Area B. It is assumed that the generators in each area have sufficient capacity to satisfy the entire load. If the incremental costs in Area A is 20 \$/MWh, and that of Area B is 50 \$/MWh, the pure economic dispatch solution would be as shown in Fig. 1(a) and the total operating cost would be equal to 32,000\$/h. Suppose now that the N-1 criterion is applied to enhance system security to an acceptable level. This requires that the system should have no limit violations if one of the lines trips. It is clear from

Fig. 1(b) that the resulting security-constrained dispatch has a higher operating cost (38,000 \$/h) than the pure economic dispatch shown in Fig. 1(a). Let us now consider that a WADC is implemented in the system to improve the damping of the critical inter-area mode and increase transmission capacity. With WADC, it is assumed that the capacity of each line is increased to 350 MW. Fig. 1(c) shows the resulting security-constrained dispatch with operating cost equal to 29,000 \$/h. Hence, an economic benefit is gained with the application of WADC. However, the failure of the WADC under certain stringent conditions such as loss of remote signal may pose a serious threat to the dynamic security of the system. Therefore, a failure of a WADC should be considered as a part of the N-1 criterion. In this case, the resulting security-constrained dispatch will be as shown in Fig. 1(a). Thus, applying the N-1 criterion on the WADC affects the operation cost. Therefore, the N-1 criterion can prevent the full exploitation of the WADC and reduce its economic benefit. This may not encourage the TSOs (Transmission System Operators) to invest in this type of control. However, as mentioned above, preventive control which utilities have relied up on in the past, is now no longer acceptable in liberalized electricity markets. Consequently, the monitoring and control measures have shifted from the preventive to the emergency ones [37]. Since it is only triggered if the postulated harmful contingency occurs, emergency control does not face the trade-off between security and economics.

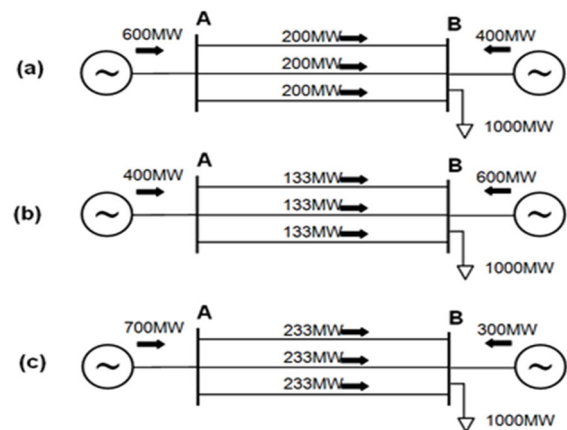

**FIGURE 1.** Two-Bus power system. (a) Unsecured operation (i.e. pure economic dispatch). (b) Operation under the N-1 security rule (i.e. security-constrained dispatch). (c) Security constrained dispatch when the capacity of each line is increased to 350 MW.

Suppose, for example, that the generators in Areas A and B can increase/decrease their power outputs by 100 MW before the system protection is triggered. Considering this corrective action, the dispatch shown in Fig. 1(c) is obtained. Therefore, the same level of security is obtained as with the preventive control shown in Fig. 1(b), but with a lower operating cost. However, it is difficult to achieve a corrective post-contingency action in a reliable manner given that the speed of response is a crucial factor. For inter-area oscillatory

instability, sufficient time is usually available to detect the incident and take appropriate action to damp the unstable modes before the oscillations become too large to lead to system separation [1], [2]. So far, a limited number of studies have focused on designing emergency control actions to suppress inter-area power oscillations during system contingencies [32], [33], [34], [35], [36]. Most of these actions induce a cost because they are often based on generation re-dispatch and load shedding procedures. However, there may be other possible emergency actions which would minimize or avoid the use of generation re-dispatch and load shedding when oscillatory instability is caused by the failure of a WADC. In the next sections, effective and reliable emergency actions are proposed to ensure the full exploitation of the WADC while avoiding or minimizing the economic penalties incurred when using costly actions.

### III. WADC STRUCTURE AND POSSIBLE FAILURES

#### A. STRUCTURE

To provide effective emergency actions to counteract the sudden loss of remote signals, it is very important to analyse the structure of the WADCs. Different control structures have been proposed to implement WADCs in power systems. Among these, the centralized structure with hierarchical scheme is the most used in the literature. In this structure, the WADC is located in the control center close or embedded in the PDC (Phasor Data Concentrator). It receives the inputs signals from local measurement units and sends control signals back to the local control devices, i.e. AVR (Automatic Voltage Regulators) of the generators, or in some cases FACTS devices or HVDC links as shown in Fig. 2.

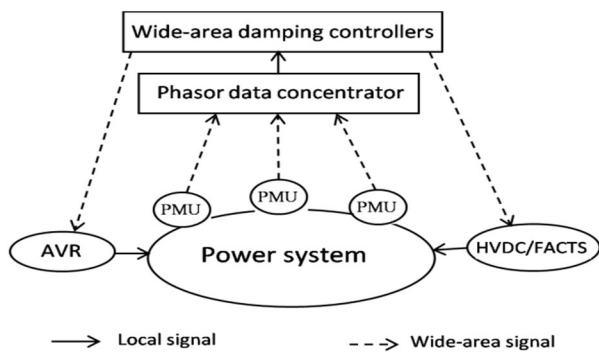

FIGURE 2. General structure of wide-area damping control.

This hierarchical scheme comprises two control levels as shown in Fig. 3. The first level is the existing decentralized local controllers (i.e., local PSS), and the second level is the centralized controllers (i.e., WADC). Several WADCs can be used to improve the damping of the dominant inter-area modes, thereby improving the overall stability of the interconnected system. The controllers are designed sequentially using a decentralized approach, which means, design

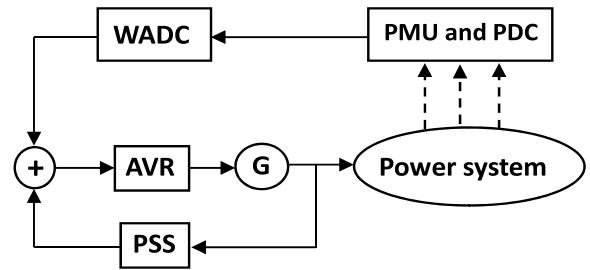

FIGURE 3. Two-level control structure.

the damping controller for one device, and then proceed to close the loop before designing the next control loop [38]. The main advantage of this hierarchical scheme is that if a failure occurs in the WADC communication links, a minimal damping action will still be provided by the decentralized level (i.e. local controller). The wide-area control levels are only used to improve the damping of some specific inter-area modes, which means that only a few WADCs will be needed. Generally, the WADC is used to damp the critical inter-area mode that cannot be adequately damped using local PSSs, i.e. the situation where the mode is not as highly controllable and observable in the generator’s local signals.

#### B. INPUT SIGNAL

The feedback signal must possess high observability of the mode to be damped. Several approaches have been used to select effective input signals to WADCs, such as residues and geometric measures [39]. The most commonly used signals are the speed difference, tie-line active power, generator angle, voltage and current magnitude and angle. As suggested in several studies, using the speed difference as an input signal to WADCs could be an effective way for improving damping of inter-area modes and has been widely used [4], [6], [7].

#### C. POSSIBLE FAILURES

Based on the structure given in Fig. 2, the following possible failures may occur:

- Loss of remote signals acquired by PMUs, e.g. due to communication failure. This type of failure is called sensor failure and can be detected at the receiving end of the WADC in the PDC,
- Loss of the remote control signal produced by the WADC. This type of failure is called actuator failure.

Failures such as loss of communication could be detected using time-stamped phasor measurements or a protocol with immediate acknowledgment (ACK) [25], [26]. However, cyber attacks could be cleverly designed, which makes their detection a difficult task, especially attacks that target integrity [40], [41], [42]. Therefore, effective techniques must be used to detect these types of attacks. This issue has been extensively addressed in the literature and is beyond the scope of this paper.



#### IV. RESIDUE METHOD

The linearized model of the power system can be described by the following state equation:

$$\begin{cases} \dot{x} = Ax + Bu \\ y = Cx \end{cases} \quad (1)$$

where  $x$ ,  $u$  and  $y$  are the state, input and output vectors, respectively.  $A$ ,  $B$  and  $C$  are state, input and output matrices, respectively.

An eigenanalysis of matrix  $A$  produces the eigenvalues  $\lambda_i$  and their corresponding right and left eigenvectors  $e_i$ ,  $v_i$ , respectively. System oscillations are identified from the eigenvalues and damping controllers are designed to improve the damping of one or more of these modes.

The system transfer function can be obtained as follows:

$$\frac{y(s)}{u(s)} = C(sI - A)^{-1} \cdot B = \sum_{i=1}^n \frac{R_i}{s - \lambda_i} \quad (2)$$

where  $R_i$  is the residue associated with mode  $\lambda_i$  and represents an index containing the controllability and the observability information. It is given by:

$$R_i = C \cdot e_i \cdot v_i^T \cdot B \quad (3)$$

The controllability of mode  $i$  from the  $j^{\text{th}}$  input is given by  $|v_i B_j|$ , whereas the observability of mode  $i$  from the  $j^{\text{th}}$  output is given by  $|C_j e_i|$ .

If a WADC with transfer function  $H(s)$  is installed to improve the damping of mode  $i$ , the eigenvalues of the new system are the roots of:

$$1 + H(s) \sum_{i=1}^n \frac{R_i}{s - \lambda_i} = 0 \quad (4)$$

Since the shift  $\Delta\lambda_i$  introduced to  $\lambda_i$  is relatively small, therefore  $\Delta\lambda_i$  can be expressed as follows:

$$\Delta\lambda_i = R_i \cdot H(\lambda_i) \quad (5)$$

A WADC is usually a lead-lag compensation controller and its transfer function is given by

$$H(s) = K \frac{T_w s}{1 + T_w s} \left( \frac{1 + T_1 s}{1 + T_2 s} \right)^m \quad (6)$$

where  $T_w$  is the wash-out time constant (usually 5-10 s),  $T_1$ ,  $T_2$  are controller time constants,  $K$  is a positive constant gain and  $m$  is the number of lead-lag blocks (usually chosen 2).

The residue magnitude  $|R_i|$  decides the gain of  $H(s)$  whereas the angle of the residue indicates the required phase compensation for each mode to achieve damping effect. Since the high value of  $|R_i|$  is required to obtain a good damping performance, the signal with the highest observability is chosen as an input to the WADC.

The required phase compensation for mode  $\lambda_i$  is given by:

$$\varphi_i = 180^\circ - \arg(R_i) \quad (7)$$

The time constants  $T_1$ ,  $T_2$  can be determined as follows [6]:

$$\alpha = \frac{T_1}{T_2} = \frac{1 - \sin\left(\frac{\varphi_i}{m}\right)}{1 + \sin\left(\frac{\varphi_i}{m}\right)} \quad (8)$$

$$T_2 = \frac{1}{2\pi f_i \sqrt{\alpha}} \quad (9)$$

$$T_1 = \alpha T_2 \quad (10)$$

where  $f_i$  is the frequency of the  $i^{\text{th}}$  mode.

#### V. PROPOSED EMERGENCY CONTROL STRATEGY

##### A. OVERVIEW OF THE PROPOSED SCHEME

Fig. 4 presents a flowchart describing the proposed emergency control strategy. It should be noted that this scheme is designed to address only oscillations problems associated with WADC failures. It can be incorporated into existing real-time emergency control programs addressing inter-area oscillations problems. The aim of the proposed control is to avoid or minimize the economic penalties incurred by the generation re-dispatch method. To achieve this goal, the proposed control should be applied prior to the generation re-dispatch procedures. If the impact of the available designed corrective actions is not sufficient to achieve the suitable damping of the mode of concern, generation re-dispatch procedure should be called upon to achieve the desired damping.

Since the possible failures of the WADC are well known, the presented emergency control is proposed to operate in an event-driven approach. This means that the corrective actions are determined off-line and triggered once the relevant failures are detected. The proposed event-driven emergency control can be designed as follows:

- 1) Identify the possible failures of the WADC
- 2) Determine the appropriate corrective actions for each failure
- 3) For each defined failure, verify if the determined corrective actions are sufficient to move the operating point to a secure state, or if additional actions (probably more costly) may be considered, such as generation re-dispatch.
- 4) Investigate if the effectiveness of the chosen corrective actions is ensured for a wide range of operating conditions of the system. When effectiveness is not ensured for any operating point, then new appropriate corrective actions must be defined for that operating point.
- 5) Update the control action lists in the database.

In order to update the control lists, Step 3 should be performed periodically, especially when the operating conditions vary, or a change occurs in the physical network topology. The appropriate list for each operating condition will be defined through Step 4. If the appropriate list is not detected, or if the control actions in the detected list are not sufficient to ensure adequate damping, then generation re-dispatch procedure should be applied.

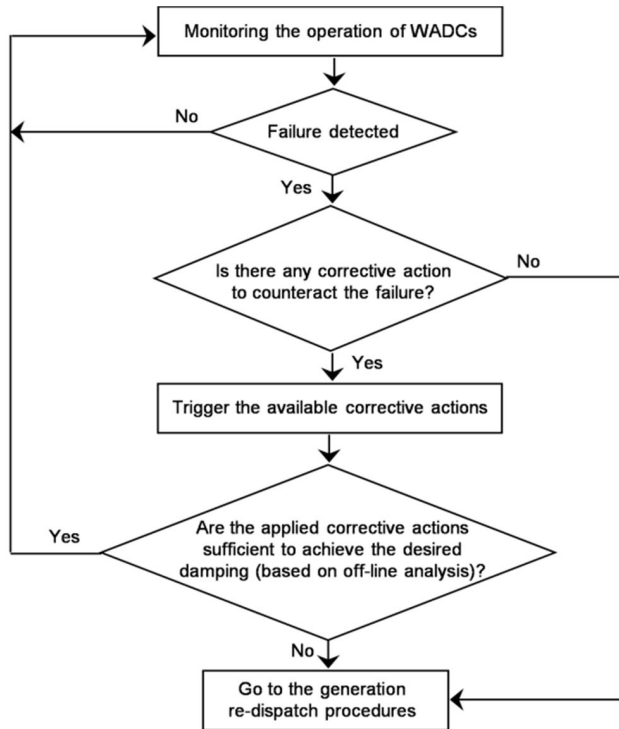

**FIGURE 4.** Flowchart illustrating the proposed emergency damping control.

## B. CORRECTIVE ACTIONS

Robust control techniques are not sufficient to counteract the loss of wide-area signals and can only be used in preventive schemes [21], [26]. The only possible corrective action to handle sensor failures is to apply another signal, among the available measurement signals, with higher observability of the mode of concern. Recently, with the large-scale adoption of WAMS technology and the availability of large amount of real-time data at the control center, this technique has become more attractive and feasible. However, to switch from a faulty communication channel to a healthy communication channel, another controller is required which means that several controllers must be designed, together with a switching strategy. This approach is proposed in [25], where a set of SISO (Single-Input Single-Output) damping controllers have been designed, with one controller for each measurement. While this method is effective to counteract communication failures, as the number of controllers increases, the cost and complexity of the system increase [21], [22]. To overcome this problem and reduce the number of controllers, this paper proposes a criterion to select signals that can be applied to the same controller. Based on this criterion, the selected healthy signal can be applied without the need for another controller and it can provide a similar (or slightly inferior) damping effect to that provided by the faulty signal. Note that in this paper, the faulty signal will also be referred to as the original signal.

In addition to the observability index, which is an important criterion for selecting the signal that could replace the faulty

signal, we include a second criterion which is the phase angle of the corresponding residue. As stated in Section IV (equation (7)), the phase compensation required to provide a damping effect at each mode is related to the phase angle of the corresponding residue. Therefore, if the phase angle of the residue associated with a chosen feedback signal is close to that associated with the faulty feedback signal with respect to the concerned inter-area mode, it is expected that this chosen feedback signal can provide a damping to this mode through the same controller. The damping effect provided by the chosen feedback signal is related to its observability index of the mode of concern. The criterion for selecting the feedback signals is given then by:

$$\phi_i^k(j) - \varphi_i \leq \gamma, j = 1, 2, \dots \quad (11)$$

where  $\phi_i^k(j)$  is the angle of the residue for the  $i^{\text{th}}$  mode associated with the candidate signal  $k$  at the operating condition  $j$ ,  $\varphi_i$  is the angle of the residue for the  $i^{\text{th}}$  mode associated with the original signal at the nominal operating condition (i.e. the residue at which the controller has been designed), and  $\gamma$  is a defined threshold to ensure damping effect (typically: 10-15 degrees [43]). The difference given by (11) will be referred to as residue angle difference throughout this paper. Instead of designing a set of SISO controllers (one for each measurement as in [25]), the proposed criterion allows using multiple measurements for one controller. After applying the criterion to the available candidate signals, the selected signals will be sorted in a descending order in terms of their damping effects (i.e. their observability indices). Once the original signal of a WADC encounters a communication failure, a healthy signal in the corresponding list is used to ensure adequate damping performance. If the selected signal fails to provide sufficient damping performance, generation re-dispatch procedure should be called upon to achieve the desired damping performance.

## C. ACTUATOR FAILURES

The actuator failures can be handled by redistributing the control signals to other available actuators using reconfiguration control schemes [26], [27]. In this case, our proposed criterion is also applicable to this type of failure and avoids the design of complex reconfiguration schemes. When identifying potential feedback signals that could replace the original signal (sensor failure), the residue of the transfer function relating the input of the original actuator and the candidate feedback signals will be computed. While, when identifying potential actuators that could replace the original actuator (actuator failure), the residue of the transfer function relating the original feedback signal and the inputs of the candidate actuators will be computed. The actuators selected using the proposed criterion will be sorted in a descending order in terms of their controllability indices. When an actuator failure is detected, the actuator with the largest damping effect in the corresponding list will be used first to improve the damping. If the desired performance is not achieved, the second actuator in the corresponding list will be used

to meet the desired performance, and so on. If all available actuators fail to provide adequate damping performance, then generation re-dispatch procedure should be used to meet the desired damping. From the above, it can be concluded that the proposed criterion can also be used to find suitable feedback signal and actuator when sensor and actuator failures occur simultaneously. To do so, the residues of the transfer function relating the inputs of the candidate actuators and the candidate feedback signals are computed. This is another advantage of the proposed method compared to the previous methods. A further analysis should be carried-out to verify that the use of any signal/actuator from the list does not adversely affect the damping of the other modes.

It should be noted that there is a time delay associated with each feedback input signal and also a time delay associated with each actuator (i.e. the delay needed to transmit the control signal). These delays can adversely impact the damping performance of the controllers which need to be considered in the design of the controller. Many studies have addressed this issue and good results have been achieved [12], [13], [14], [15], [16], [17]. Time delays are not considered in this paper and the feedback signals are assumed to be readily available to the controller. This assumption will not affect the validity of our proposed approach.

#### D. COHERENCY CONCEPT TO HELP FIND APPROPRIATE FEEDBACK SIGNALS/ACTUATORS

It is well known that an inter-area oscillation appears as a coherent group of generators in one area oscillating against a coherent group of generators in another area. Since coherent generators behave identically in low frequency oscillations [44], the coherency concept can be used to narrow down the locations of potential feedback signals and actuators in the selection process. This concept can help the designer to find the appropriate feedback signals/actuators from a set of candidate signals/actuators. Signals of the same nature as the faulty signal within the same coherent group of generators are more likely to fulfil the proposed criterion. Also, generators within the same coherent group of the faulty actuator (generator) are more likely to meet the criterion.

#### E. MODAL DECOMPOSITION CONTROL TO ALLEVIATE THE INTERACTION PROBLEM

With the wide-scale deployment of WAMS technology in an attempt to make the grid smarter, the probability of finding signals that meet the proposed criterion to replace the original signals is high in modern power systems. However, fulfilling the proposed criterion does not mean that the chosen signal is a good candidate to replace to original signal. Indeed, the chosen signal will provide damping to the concerned mode but may have a negative impact on the damping of the other modes. This problem could greatly reduce the probability of finding suitable signals to replace the original signals. To overcome this problem, Modal Decomposition Control (MDC) method is used in this study to eliminate

interactions between different modes. MDC provides a powerful means for allowing WADC focuses on improving the damping of the concerned mode without affecting other modes. A brief review of the MDC method is described here and for more details, the reader is referred to [45].

Using the eigenvectors, the modal properties of the system given by equation (1) are:

$$AE = E\Lambda, V^T E = I \quad (12)$$

where  $E$  and  $V$  are the matrices of the right and left eigenvectors of  $A$ , respectively,  $\Lambda$  is a diagonal matrix containing the system eigenvalues and  $I$  is an identity matrix.

Using the linear transformation:

$$x = Ez \quad (13)$$

where  $z$  is the state vector in the new coordinates. The system in (1) can be given by:

$$\dot{z} = \Lambda z + V^T B u \quad (14)$$

$$y = CEz = \sum_{i=1}^n C e_i z_i \quad (15)$$

Considering that a WADC with transfer function  $H(s)$  is installed at the  $j^{\text{th}}$  output and  $k^{\text{th}}$  input. If the output  $y_j$  is a sole modal signal consisting only of information of the corresponding mode, we can write:

$$y_j = C_j \cdot e_i \cdot z_i \quad (16)$$

where  $z_i$  is the  $i^{\text{th}}$  component of  $z$ . Then, the control input can be given as:

$$u_k = H(s) \cdot C_j \cdot e_i \cdot z_i \quad (17)$$

The state equations become:

$$\dot{z} = \Lambda z + V^T B_k H(s) C_j e_i z_i = A^* \cdot z \quad (18)$$

where  $A^*$  is the transformed system matrix in the new coordinates:

$$A^* = \begin{bmatrix} \lambda_1 & 0 \cdots & v_1^T B_k H(s) C_j e_i \cdots & 0 \\ 0 & \lambda_2 \cdots & v_2^T B_k H(s) C_j e_i \cdots & 0 \\ \vdots & \ddots & \ddots & \vdots \\ 0 & 0 \cdots & \lambda_i + v_i^T B_k H(s) C_j e_i \cdots & 0 \\ \vdots & \ddots & \ddots & \vdots \\ 0 & 0 \cdots & v_n^T B_k H(s) C_j e_i \cdots & \lambda_n \end{bmatrix} \quad (19)$$

The eigenvalues of the closed-loop system can be obtained by solving:

$$\det(sI - A^*) = 0 \quad (20)$$

From (19) it is clear that the feedback control will only modify the  $i^{\text{th}}$  mode and will have no effect on the other modes. The change of the concerned mode  $y_i$  can be calculated using equation (5). The controller phase compensation calculated by (7) will allow the  $i^{\text{th}}$  mode to be shifted to the left half-plane, horizontally, without changing its frequency.

To apply the method to controller design, a finely tuned filter can be used to obtain an approximate sole modal signal by preserving the concerned mode while annihilating the other modes. To improve the performance of the filter, a feedback signal with good observability of the concerned mode must be chosen. It has been found that a second order band pass filter works well and provides satisfactory performance [45]. Its transfer function is given by

$$F(s) = \frac{\frac{\omega_0}{Q}s}{s^2 + \frac{\omega_0}{Q}s + \omega_0^2} \quad (21)$$

where  $\omega_0$  is the pass-band central frequency (it is also the frequency of the concerned mode) and  $Q$  is a quality index. The structure of the WADC and the added filter is shown in Fig. 5. The filter is used only when the selected signal has a negative effect on the other modes. The filter can provide satisfactory performance when the frequency of the concerned mode varies within the range of  $\pm 10\%$ . Furthermore, it has been shown that an inter-area mode frequency rarely varies beyond  $\pm 10\%$  [45]. Therefore, the filter can provide robust performance over a range of operating conditions.

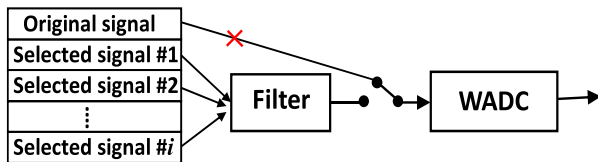

FIGURE 5. WADC with filter.

## VI. TEST CASES

### A. NOMINAL TEST SYSTEM

The method is tested in the well-known four-machine, two-area system shown in Fig. 6. Further details of the system can be found in [46]. All the generators are equipped with fast static exciters and governors, and the system is operating with Area 1 exporting 413 MW to Area 2. The system is implemented in MATLAB/Simulink. Small signal analysis shows that the system has three electromechanical modes shown in Table 1. The system exhibits one unstable inter-area mode at 0.64 Hz in which the whole area 1 oscillates against area 2. An original PSS from [46] is attached to generator G2.

The PSS at G2 does not provide sufficient damping improvement to the inter-area mode and the mode is still unstable with a damping of -0.4%. This is because this mode is not well observable in the locally available signals. As indicated in several studies, to ensure good damping of this critical mode, a WADC is required. Thus, we will design a WADC working in parallel with the local PSS at G2, which is expected to provide high damping ( $\zeta > 10\%$ ) to the inter-area mode because this mode is strongly controllable in G2.

Based on the observability indices associated with the rotor speeds shown in Table 2, the speed deviation of G3 ( $\Delta\omega_3$ ) provides the best observability of the inter-area mode and can be used as input to the WADC. Since G3 oscillates against

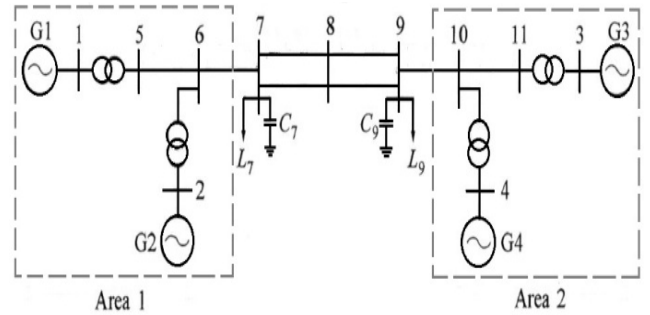

FIGURE 6. Two-area system.

TABLE 1. Electromechanical modes of oscillation.

Mode	Eigenvalue	Freq. (Hz)	Damping (%)	Mode shape
Local mode (Area 1)	$-0.676 \pm j 7.045$	1.121	9.55	G1 vs G2
Local Mode (Area 2)	$-0.668 \pm j 7.267$	1.156	9.16	G3 vs G4
Inter-Area Mode	$0.107 \pm j 4.026$	0.640	-2.68	(G1,G2) vs (G3,G4)

TABLE 2. Observability indices of inter-area mode.

Signal	$\Delta\omega_1$	$\Delta\omega_2$	$\Delta\omega_3$	$\Delta\omega_4$
obs	0.0040	0.0025	0.0063	0.0057

G1 and G2, the observability index of  $\Delta\omega_3$  can be further increased by combining it with  $\Delta\omega_1$  or  $\Delta\omega_2$ . The signal ( $\Delta\omega_1 - \Delta\omega_3$ ) is finally chosen as input, which provides high observability of the inter-area mode (0.0106). The residue phase compensation method discussed in Section IV is used to design the controller. The transfer function of the controller is:

$$H(s) = 20 \frac{10s}{1 + 10s} \left( \frac{1 + 0.2086s}{1 + 0.2752s} \right)^2$$

The designed WADC greatly improve the damping of the inter-area mode which reaches 18.75%.

A three-phase fault was applied at 1 s at the middle of the tie-lines (Bus 8 in Fig. 6) for 100 ms duration. The fault is cleared with no tie-line outage, but after 2 s (i.e. at 3 s), a communication failure is considered.

### 1) SENSOR FAILURE

The proposed criterion is used to find the suitable signals that would replace the faulty signal  $\Delta\omega_{13}$ . The computed residue angles of the transfer function relating the AVR reference input at G2 and various candidate signals shows that the signals  $\Delta\omega_{14}$ ,  $\Delta\omega_{24}$ ,  $\Delta\omega_{23}$ ,  $-\Delta\omega_3$  and  $-\Delta\omega_4$  perfectly fulfill the proposed criterion. The negative sign indicates that the rotor speed should be used with reverse. Since the original signal  $\Delta\omega_{13}$  is a combination of two signals  $\Delta\omega_1$  and  $\Delta\omega_3$ , the loss of one signal among them is a failure of the whole signal. When the signal  $\Delta\omega_3$  is lost, the signals  $\Delta\omega_{14}$ ,  $\Delta\omega_{24}$



or  $-\Delta\omega_4$  can be used as input to the WADC, while when the signal  $\Delta\omega_1$  is lost, the signals  $\Delta\omega_{23}$ ,  $\Delta\omega_{24}$ ,

$-\Delta\omega_4$  or  $-\Delta\omega_3$  can be used as input. The signals are classified according to their observability indices shown in Table 3 which also gives the damping provided by each signal.

Under nominal operating conditions, the difference between the residue angle for the inter-area mode associated with the original signal and the residue angles associated with the chosen signals (i.e. the residue angle difference given by (11)) does not exceed  $4^\circ$ . However, as the operating conditions change, the magnitude and angle of the residue will vary. It is therefore important to verify that the selected signals meet the proposed criterion over a wide range of operating conditions. In the present study, various system operations are obtained by varying the power output of the generators, load demands, and N-1 outage contingency of the lines and generators. Each generator output and load demand is varying within a range of  $\pm 30\%$  (with each step 50MW) from its nominal operating condition. The case of a generator outage is modeled by setting its output to zero. A total of 57 operations are obtained. Fig. 7 and Fig. 8 show the variation of the absolute amplitude value and angle of the residue for the selected signals computed for all the chosen operating conditions.

TABLE 3. Observability and damping at nominal operating point.

Signal	$\Delta\omega_{13}$	$\Delta\omega_{14}$	$\Delta\omega_{23}$	$\Delta\omega_{24}$	$-\Delta\omega_3$	$-\Delta\omega_4$
obs	0.0106	0.0099	0.0085	0.0078	0.0063	0.0057
Damping (%)	18.75	15.46	5.07	4.27	5.04	4.00

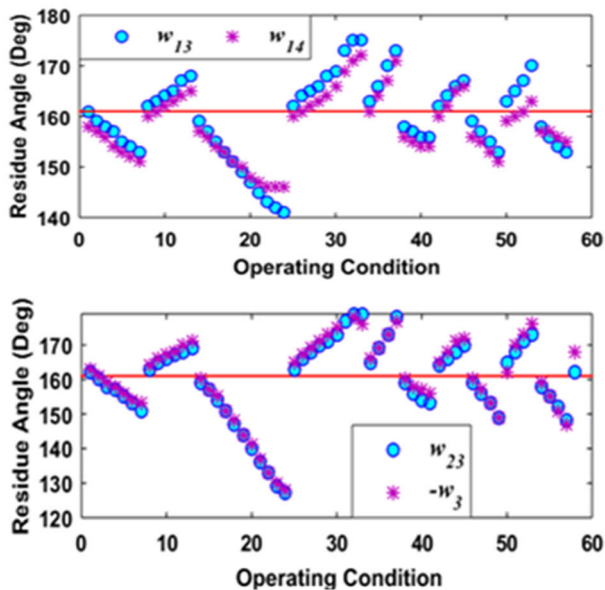

FIGURE 7. Variation in phase angle of the residues.

For comparison, the variations for the original signal are also shown in the figures. Nominal operating point is

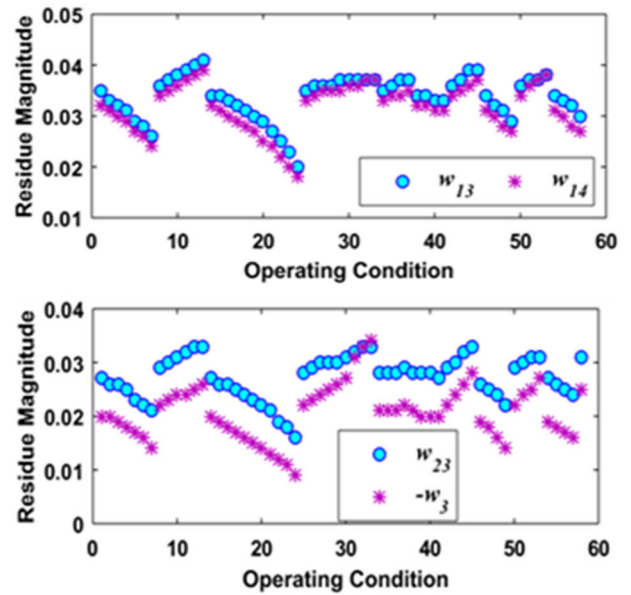

FIGURE 8. Variation in magnitude of the residues.

represented by a straight red line. Signals  $\Delta\omega_{14}$  and  $\Delta\omega_{13}$  show similar variation in both angle and magnitude. Similar variation is also shown for signals  $\Delta\omega_{24}$ ,  $\Delta\omega_{23}$ ,  $-\Delta\omega_3$  and  $-\Delta\omega_4$  (the variation for the signals  $\Delta\omega_{24}$  and  $-\Delta\omega_4$  are not shown in the figure). It can be observed that the signals  $\Delta\omega_{14}$  and  $\Delta\omega_{13}$  have relatively less variation compared to the other signals. The worst case scenario in which the residue angle difference reaches its highest values is obtained when the load demand at bus 9 is reduced by 30%. This is the case for all the chosen signals. Under this condition, the power transfer is from area 2 to area 1 (62 MW). At this operation point, the residue angle difference reaches  $15^\circ$  for the signal  $\Delta\omega_{14}$ , whereas for the other signals it reaches up to  $34^\circ$ . Moreover, the residue magnitude reaches its minimum value at this operating point for all signals. Thus, if any of the chosen signals can provide sufficient damping at this operating condition, it will provide sufficient damping at all the other operating conditions. The damping provided at this operating point by each of these signals is given in Table 4. It can be shown that the damping provided by  $\Delta\omega_{13}$  and  $\Delta\omega_{14}$  is acceptable, whereas the damping provided by the other signals is weak and hence additional measures may be required.

Fig. 9 and Fig. 10 show the system responses for the above contingency for both cases with corrective action (curves WC) and without corrective action (curves NC). The case without communication failure (curves NF) is also shown in the figures. The figures show the tie-line power oscillations. Fig. 11 shows the responses when the corrective actions are applied after delays that represent the time required to detect the failure and identify the suitable input signal.

It can be observed from the figures that with the proposed control, the system is well damped after the communication failure which agrees with the results in Table 3. It can be

seen that a delay of 2 s has minor effect, which means that there is sufficient time to detect the failure and identify the corresponding appropriate input signal.

TABLE 4. Damping for the worst case scenario.

Signal	$\Delta\omega_{13}$	$\Delta\omega_{14}$	$\Delta\omega_{24}$	$\Delta\omega_{23}$	$-\Delta\omega_3$	$-\Delta\omega_4$
Damping (%)	5.61	6.06	2.62	2.52	2.34	2.37

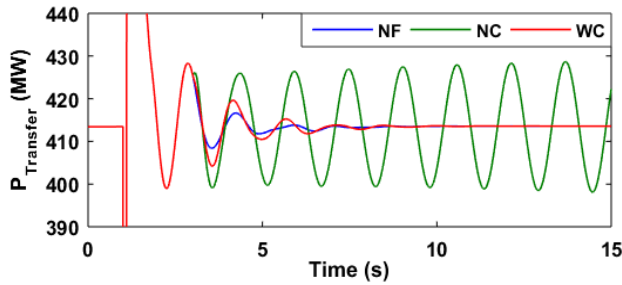

FIGURE 9. Responses when  $\Delta\omega_3$  is lost and  $\Delta\omega_{14}$  is used as input.

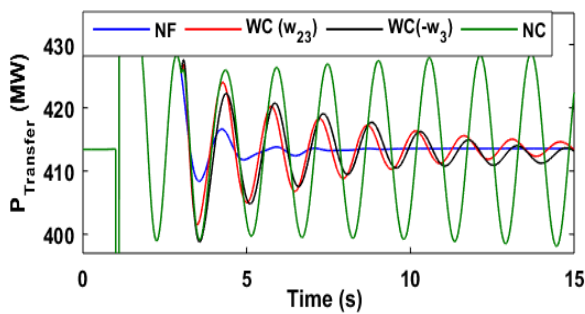

FIGURE 10. Responses when  $\Delta\omega_1$  is lost and  $\Delta\omega_{23}$  or  $-\Delta\omega_3$  is used as input.

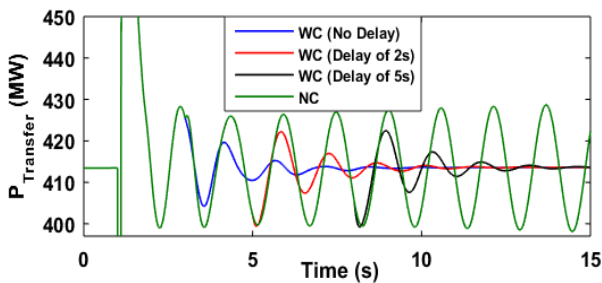

FIGURE 11. Responses when  $\Delta\omega_3$  is lost and  $\Delta\omega_{14}$  is used as input with different time delays.

## 2) ACTUATOR FAILURE

The analysis shows that generator G1 meets the proposed criterion and can be used when an actuator failure occurs. The residue angle difference (i.e. the difference between the residue angle for the inter-area mode associated with

the output  $\Delta\omega_{13}$  and the input G2, and the residue angle associated with the output  $\Delta\omega_{13}$  and the input G1) is  $10^\circ$  at nominal operating condition. When G1 is used as an actuator, a damping of 12.19% is obtained under nominal operating condition.

Fig. 12 shows the variation of residue angle for the selected operating conditions. The nominal operating point is shown as a straight red line. It is clear that the signal  $\Delta\omega_{13}$  with G1 shows less variation in the residue angle compared with G2 shown in Fig. 7. The worst case scenario in which the residue angle difference reaches its highest values is obtained when the output of G1 is decreased by 30%. At this operation point, the residue angle difference reaches  $17^\circ$  and the obtained damping is 10.88%.

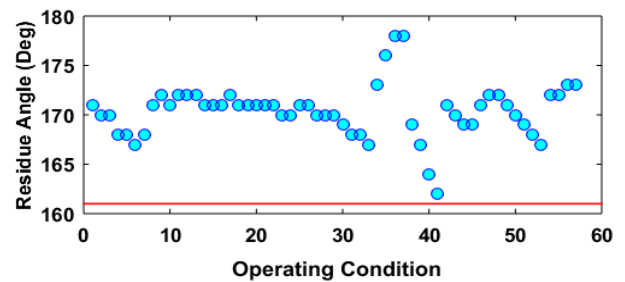

FIGURE 12. Variation in phase angle of the residues (Output:  $\Delta\omega_{13}$ , Input: G1).

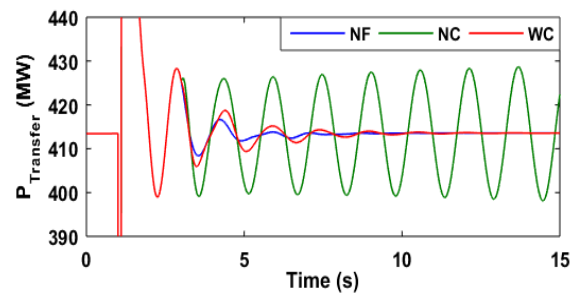

FIGURE 13. Responses when the control signal to G2 is lost and G1 is used as an actuator.

Fig. 13 shows the system responses for the defined contingency. The proposed control works well and ensures good damping performance after the failure.

## B. APPLICATION TO STATIC VAR COMPENSATOR (SVC)

A static VAR compensator (SVC) belongs to the family of FACTS devices and has been widely used in power systems for enhancing voltage control. By using a supplementary damping controller, the SVC can also be used to improve the damping of inter-area oscillations. To verify the effectiveness of our proposed approach, a SVC with a capacity of  $\pm 200$  MVar is used in this section. As recommended in several studies [16], [47], the SVC is installed at the mid-point of the tie-lines (Bus 8 in Fig. 6). The residues corresponding to the inter-area mode for the transfer function

between voltage reference input of the SVC and various feedback signals are calculated to select to best input signal. The current magnitude between buses 8 and 9 ( $I_{89}$ ) is chosen for the damping controller. Several studies have also shown that current magnitude is the most suitable feedback signal for SVC for damping enhancement [48]. The residue phase compensation method is used to design the controller. The transfer function of the controller is:

$$H(s) = 3 \frac{10s}{1 + 10s} \left( \frac{1 + 0.1168s}{1 + 0.5133s} \right)^2$$

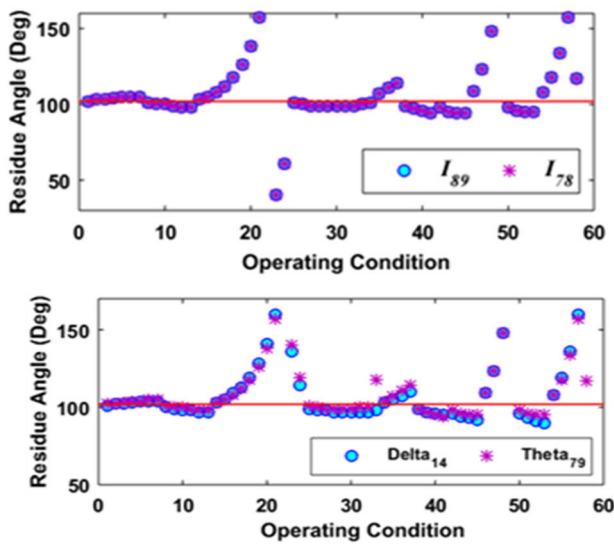

FIGURE 14. Variation in phase angle of the residue.

TABLE 5. Damping at nominal operating point.

Signal	$I_{89}$	$I_{78}$	$\Delta\delta_{14}$	$\Delta\theta_{79}$
Damping (%)	7.14	6.42	8.12	7.97

The designed WADC improves the damping of the inter-area mode which reaches 7.14%. The damping can be further improved by increasing the controller gain. However, this will have a negative impact on other modes. It should be noted that the WADC applied at G2 is not used here.

### 1) SENSOR FAILURE

The proposed criterion is used to find the suitable signals that would replace the faulty signal  $I_{89}$ . Computing the residue angles of the transfer function relating the SVC reference input and various candidate signals shows that several signals fulfill the proposed criterion. The signals are: active power flows ( $P_{78}$ ,  $P_{67}$ ), current magnitudes ( $I_{78}$ ,  $I_{67}$ ), generator rotor angle differences ( $\Delta\delta_{14}$ ,  $\Delta\delta_{13}$ ,  $\Delta\delta_{24}$ ), and the voltage angle difference between bus 7 and bus 9 ( $\Delta\theta_{79}$ ). To test the proposed approach, we have chosen the three signals:  $I_{78}$ ,  $\Delta\delta_{14}$ , and  $\Delta\theta_{79}$ .

Fig. 14 shows the variation of residue angles of the selected signals computed for the defined operating conditions. Similar variation trend can be observed. For all the chosen signals, the residue angle has a value close to its nominal value for most of the operating conditions. However, a large variation is observed under certain operating points (when the load demand at bus 9 is decreased, and when the output of G3 or G4 is increased) in which the residue angle difference reaches a value of  $55^\circ$  (worst case scenario). The analysis shows that the damping of the inter-area mode is not satisfactory ( $< 5\%$ ) when the residue angle difference exceeds  $20^\circ$  for all the chosen signals including the original signal ( $I_{89}$ ). Table 5 shows the damping provided by each signal at the nominal operating point. The signal  $\Delta\delta_{14}$  provides good damping for the inter-area mode, however, it destabilizes another mode (0.025 Hz). Therefore, to overcome this problem and allow the signal  $\Delta\delta_{14}$  to be used, the MDC technique described above will be used here. For filter design, the center frequency of the filter is 3.991 rad/s and the quality factor is 2.

The transfer function of the filter is:

$$F(s) = \frac{1.995s}{s^2 + 1.995s + 15.921}$$

The designed filter not only eliminates the interaction of WADC with other modes, but also improves its damping performance. After adding the filter, the damping of the inter-area mode becomes 13.13%. The filter will be used with feedback signals that negatively impact other modes, as shown in Fig. 5. However, as the filter improves the performance of the damping controller, it can also be used with all signals to further increase the damping of the concerned mode. When the filter is used with the original signal ( $I_{89}$ ), the damping of the inter-area mode is increased to 11.53%.

Fig. 15 shows the system responses for the defined contingency. It can be seen that the control works well and the chosen signals have effectively replaced the original signal ensuring good damping performance after the failure. It should be noted that the signal  $\Delta\delta_{14}$  was used with the designed filter, which justifies the good damping shown in Fig. 15.

### 2) ACTUATOR FAILURE

The analysis shows that all the generators meet the proposed criterion and can be used during actuator failure except G2. The residue angle differences under nominal operating condition are:  $4^\circ$  with G1 and  $8^\circ$  with G3 and G4 (recall that  $I_{89}$  is the output). A very less variation in the residue angle is observed for the three generators. Fig. 16 shows the variation of the residue angle for G1. Although G1, G3 and G4 meet the criterion, they cannot be used as an actuator due to a severe saturation problem as the output of the WADC hits its limit for a while. To overcome this problem, a low controller gain can be used during the control period. For example, a gain of 0.3 allows G4 to be used as an actuator giving a damping of 7%.

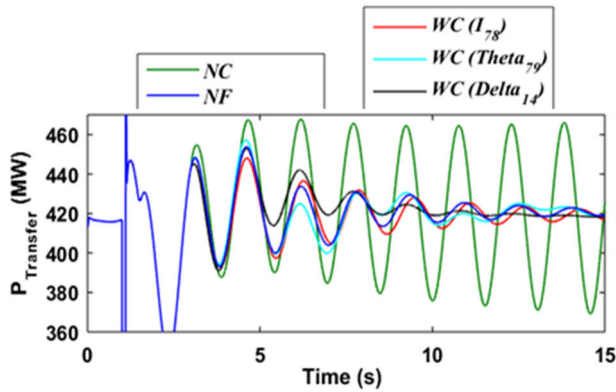

FIGURE 15. Responses when  $I_{89}$  is lost and  $I_{78}$ ,  $\Delta\delta_{14}$ , or  $\Delta\theta_{79}$  is used as input.

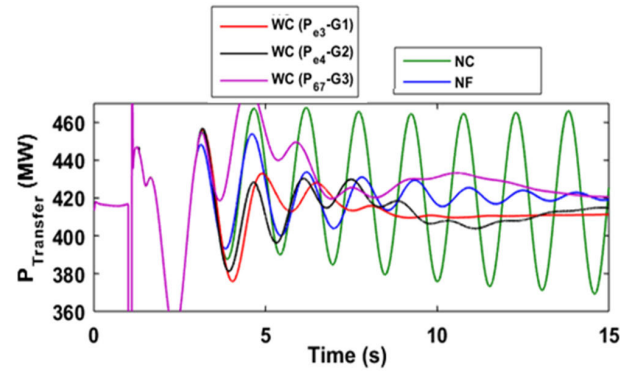

FIGURE 18. Responses with different actuators and inputs.

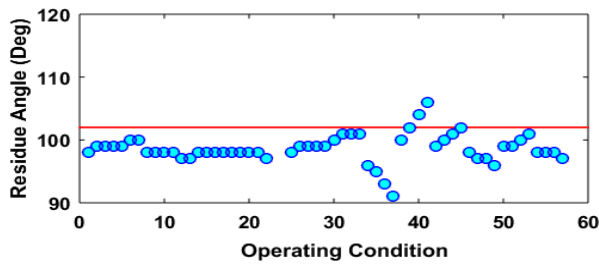

FIGURE 16. Variation in phase angle of the residue (Output:  $I_{89}$ , Input: G1).

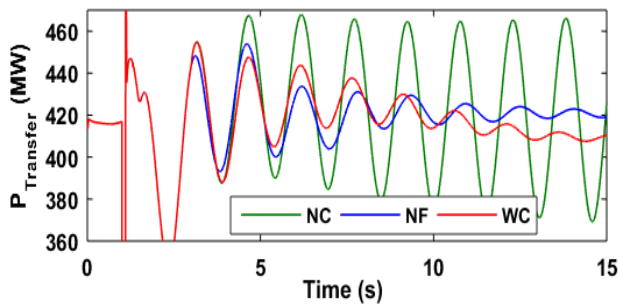

FIGURE 17. Responses when the control signal to SVC is lost and G4 is used as an actuator with a gain of 0.3.

Fig. 17 shows the system responses when G4 is used as an actuator with a gain of 0.3. As can be seen from the figure, good damping performance is ensured after the failure. However, we can avoid changing the controller gain by using another feedback signal from the real-time data available at the control centre. Based on the proposed criterion, Table 6 shows the possible feedback signals and their associated actuators as well as the obtained damping. In Table 6,  $P_{ei}$  represents the electrical power output of generator  $i$ . Fig. 18 shows the simulation results for selected actuators and inputs. The actuators and inputs are: G1 with  $P_{e1}$  as input, G2 with  $P_{e4}$ , and G3 with  $P_{67}$ . The simulation results confirm the results of Table 6 and demonstrate the validity of the proposed approach. The simulation results also confirm the validity of

the approach when both sensor and actuator failures occur simultaneously.

TABLE 6. Possible feedback signals and their associated actuators.

Actuator	Feedback signal and damping
G1	$P_{67}$ (10.13%), $I_{67}$ (17.14%), $P_{e3}$ (19%), $P_{e4}$ (17.33%)
G2	$P_{e3}$ (12.81%), $P_{e4}$ (10.24%)
G3	$P_{67}$ (14%), $I_{67}$ (15.11%), $P_{e1}$ (15.33%)

## VII. CONCLUSION

This paper presented a new emergency control scheme to ensure power system stability when communication failure occurs in the WADC channels. The proposed control is based on a criterion that gives the possibility to replace the faulty signal with a healthy signal when a sensor failure occurs without the need to use an additional controller. The criterion also makes it possible to replace the nominal actuator with other actuators without resorting to reconfiguration control schemes. The proposed criterion reduces the difficulty of dealing with communication failures and provides a more cost-effective approach compared to other existing techniques. The proposed approach is motivated by the fact that wide-area signals are transmitted independently to the PDC (i.e. through independent routes) in which a failure in one communication channel does not affect the other channels. The simulation results have demonstrated the effectiveness of the proposed control in handling communication failures and ensuring good damping performance following the loss of remote signals. The proposed control is very timely and promising due to the current growing trend to deploy WAMSs to improve monitoring and control of power systems worldwide.

## REFERENCES

- [1] H. H. Alhelou, A. Y. Abdelaziz, and P. Siano, *Wide Area Power Systems Stability, Protection, and Security*. Cham, Switzerland: Springer, 2021.
- [2] H. Wang and W. Du, *Analysis and Damping Control of Power System Low-Frequency Oscillations*. New York, NY, USA: Springer, 2016.
- [3] *Identification of Electromechanical Modes in Power Systems*, Standard TP462, IEEE Power Energy Soc., Jul. 2012.



- [4] M. Benasla, M. Denai, J. Liang, T. Allaoui, and M. Brahami, "Performance of wide-area power system stabilizers during major system upsets: Investigation and proposal of solutions," *Electr. Eng.*, vol. 103, no. 3, pp. 1417–1431, Jun. 2021.
- [5] Y. Li, D. Yang, F. Liu, Y. Cao, and C. Rehtanz, *Interconnected Power Systems: Wide-Area Dynamic Monitoring and Control Applications*. Heidelberg, Germany: Springer, 2016.
- [6] M. E. Aboul-Ela, A. A. Sallam, J. D. McCalley, and A. A. Fouad, "Damping controller design for power system oscillations using global signals," *IEEE Trans. Power Syst.*, vol. 11, no. 2, pp. 767–773, May 1996.
- [7] I. Kamwa, R. Grondin, and Y. Hebert, "Wide-area measurement based stabilizing control of large power systems—A decentralized/hierarchical approach," *IEEE Trans. Power Syst.*, vol. 16, no. 1, pp. 136–153, Feb. 2001.
- [8] Y. Zhang and A. Bose, "Design of wide-area damping controllers for inter-area oscillations," *IEEE Trans. Power Syst.*, vol. 23, no. 3, pp. 1136–1143, Aug. 2008.
- [9] W. Yao, L. Jiang, J. Wen, Q. Wu, and S. Cheng, "Wide-area damping controller for power system interarea oscillations: A networked predictive control approach," *IEEE Trans. Control Syst. Technol.*, vol. 23, no. 1, pp. 27–36, Jan. 2015.
- [10] V. V. G. Krishnan, S. C. Srivastava, and S. Chakrabarti, "A robust decentralized wide area damping controller for wind generators and FACTS controllers considering load model uncertainties," *IEEE Trans. Smart Grid*, vol. 9, no. 1, pp. 360–372, Jan. 2018.
- [11] J. Dobrowolski, P. Korba, F. R. S. Seville, and W. Sattinger, "Centralized wide area damping controller for power system oscillation problems," in *Proc. IEEE Milan PowerTech*, Milan, Italy, 2019, pp. 1–6.
- [12] B. Chaudhuri, R. Majumder, and B. C. Pal, "Wide-area measurement-based stabilizing control of power system considering signal transmission delay," *IEEE Trans. Power Syst.*, vol. 19, no. 4, pp. 1971–1979, Nov. 2004.
- [13] M. Beiraghi and A. M. Ranjbar, "Adaptive delay compensator for the robust wide-area damping controller design," *IEEE Trans. Power Syst.*, vol. 31, no. 6, pp. 4966–4976, Nov. 2016.
- [14] B. P. Padhy, S. C. Srivastava, and N. K. Verma, "A wide-area damping controller considering network input and output delays and packet drop," *IEEE Trans. Power Syst.*, vol. 32, no. 1, pp. 166–176, Jan. 2017.
- [15] M. Mokhtari, F. Aminifar, D. Nazarpour, and S. Golshannavaz, "Wide-area power oscillation damping with a fuzzy controller compensating the continuous communication delays," *IEEE Trans. Power Syst.*, vol. 28, no. 2, pp. 1997–2005, May 2013.
- [16] W. Yao, L. Jiang, J. Wen, Q. H. Wu, and S. Cheng, "Wide-area damping controller of FACTS devices for inter-area oscillations considering communication time delays," *IEEE Trans. Power Syst.*, vol. 29, no. 1, pp. 318–329, Jan. 2014.
- [17] S. Roy, A. Patel, and I. N. Kar, "Analysis and design of a wide-area damping controller for inter-area oscillation with artificially induced time delay," *IEEE Trans. Smart Grid*, vol. 10, no. 4, pp. 3654–3663, Jul. 2019.
- [18] S. Zhang and V. Vittal, "Design of wide-area power system damping controllers resilient to communication failures," *IEEE Trans. Power Syst.*, vol. 28, no. 4, pp. 4292–4300, Nov. 2013.
- [19] M. E. C. Bento and R. A. Ramos, "A method based on linear matrix inequalities to design a wide-area damping controller resilient to permanent communication failures," *IEEE Syst. J.*, vol. 15, no. 3, pp. 3832–3840, Sep. 2021.
- [20] F. R. S. Sevilla, I. M. Jaimoukha, B. Chaudhuri, and P. Korba, "A semidefinite relaxation procedure for fault-tolerant observer design," *IEEE Trans. Autom. Control*, vol. 60, no. 12, pp. 3332–3337, Dec. 2015.
- [21] M. E. C. Bento, D. Dotta, R. Kuiava, and R. A. Ramos, "A procedure to design fault-tolerant wide-area damping controllers," *IEEE Access*, vol. 6, pp. 23383–23405, 2018.
- [22] F. R. S. Sevilla, I. Jaimoukha, B. Chaudhuri, and P. Korba, "Fault-tolerant control design to enhance damping of inter-area oscillations in power grids," *Int. J. Robust Nonlinear Control*, vol. 24, nos. 8–9, pp. 1304–1316, May 2014.
- [23] M. E. C. Bento, R. Kuiava, and R. A. Ramos, "Design of wide-area damping controllers incorporating resiliency to permanent failure of remote communication links," *J. Control, Autom. Electr. Syst.*, vol. 29, no. 5, pp. 541–550, Oct. 2018.
- [24] M. Sarkar, B. Subudhi, and S. Ghosh, "Unified Smith predictor based  $H_\infty$  wide-area damping controller to improve the control resiliency to communication failure," *IEEE/CAA J. Autom. Sinica*, vol. 7, no. 2, pp. 584–596, Mar. 2020.
- [25] S. Zhang and V. Vittal, "Wide-area control resiliency using redundant communication paths," *IEEE Trans. Power Syst.*, vol. 29, no. 5, pp. 2189–2199, Sep. 2014.
- [26] M. E. Raoufat, K. Tomsovic, and S. M. Djouadi, "Virtual actuators for wide-area damping control of power systems," *IEEE Trans. Power Syst.*, vol. 31, no. 6, pp. 4703–4711, Nov. 2016.
- [27] D. V. Nair and M. Murty, "Reconfigurable control as actuator fault-tolerant control design for power oscillation damping," *Protection Control Modern Power Syst.*, vol. 5, no. 1, pp. 1–12, Feb. 2020.
- [28] F. R. S. Sevilla and P. Korba, "Semi-active wide-area fault-tolerant control in electric power systems," in *Proc. 19th World Congr. Int. Fed. Autom. Control*, South Africa, Aug. 2014, pp. 3605–3610.
- [29] J. Jiang, "Fault-tolerant control systems—An introductory overview," *Acta Autom. Sinica*, vol. 31, no. 1, pp. 161–174, Jan. 2005.
- [30] J. Lunze and J. H. Richter, "Reconfigurable fault-tolerant control: A tutorial introduction," *Eur. J. Control*, vol. 14, no. 5, pp. 359–386, Jan. 2008.
- [31] X.-Z. Jin, W.-W. Che, Z.-G. Wu, and H. Wang, "Analog control circuit designs for a class of continuous-time adaptive fault-tolerant control systems," *IEEE Trans. Cybern.*, vol. 52, no. 6, pp. 4209–4220, Jun. 2022.
- [32] C. Y. Chung, L. Wang, F. Howell, and P. Kundur, "Generation rescheduling methods to improve power transfer capability constrained by small-signal stability," *IEEE Trans. Power Syst.*, vol. 19, no. 1, pp. 524–530, Feb. 2004.
- [33] J. Cao, W. Du, H. Wang, Z. Chen, and H. F. Li, "A novel emergency damping control to suppress power system inter-area oscillations," *IEEE Trans. Power Syst.*, vol. 28, no. 3, pp. 3165–3173, Aug. 2013.
- [34] M. M. Othman and S. Busan, "A novel approach of rescheduling the critical generators for a new available transfer capability determination," *IEEE Trans. Power Syst.*, vol. 31, no. 1, pp. 3–17, Jan. 2016.
- [35] L. Yazdani and M. R. Aghamohammadi, "Damping inter-area oscillation by generation rescheduling based on wide-area measurement information," *Int. J. Elect. Power Energy Syst.*, vol. 67, pp. 138–151, May 2015.
- [36] M. Khaji and M. R. Aghamohammadi, "Online emergency damping controller to suppress power system inter-area oscillation using load-generation tripping," *Electr. Power Syst. Res.*, vol. 140, pp. 806–820, 2016.
- [37] M. Benasla, T. Allaoui, M. Brahami, V. K. Sood, and M. Denai, "Power system security enhancement by HVDC links using a closed-loop emergency control," *Electr. Power Syst. Res.*, vol. 168, pp. 228–238, Mar. 2019.
- [38] B. Chaudhuri, B. Pal, A. C. Zolotas, I. M. Jaimoukha, and T. C. Green, "Mixed-sensitivity approach to H-infinity control of power system oscillations employing multiple facts devices," *IEEE Trans. Power Syst.*, vol. 18, no. 3, pp. 1149–1156, Aug. 2003.
- [39] A. Heniche and I. Kamwa, "Assessment of two methods to select wide-area signals for power system damping control," *IEEE Trans. Power Syst.*, vol. 23, no. 2, pp. 572–581, May 2008.
- [40] M. A. Shadid, F. Ahmad, F. R. Albogamy, G. Hafeez, and Z. Ullah, "Detection and prevention of false data injection attacks in the measurement infrastructure of smart grids," *Sustainability*, vol. 14, no. 11, p. 6407, May 2022.
- [41] X. Huang and J. Dong, "Reliable leader-to-follower formation control of multiagent systems under communication quantization and attacks," *IEEE Trans. Syst., Man, Cybern. Syst.*, vol. 50, no. 1, pp. 89–99, Jan. 2020.
- [42] X. Huang and J. Dong, "An adaptive secure control scheme for T-S fuzzy systems against simultaneous stealthy sensor and actuator attacks," *IEEE Trans. Fuzzy Syst.*, vol. 29, no. 7, pp. 1978–1991, Jul. 2021.
- [43] S. Ray, B. Chaudhuri, and R. Majumder, "Appropriate signal selection for damping multi-modal oscillations using low order controllers," in *Proc. IEEE Power Energy Soc. Gen. Meeting-Convers. Del. Electr. Energy 21st Century*, Jul. 2008, pp. 1–7.
- [44] M. Benasla, T. Allaoui, and M. Brahami, "Coherency concept to increase the effectiveness of wide-area damping controller," in *Proc. 8th Int. Conf. Model., Identificat. Control (ICMIC)*, Nov. 2016, pp. 231–236.
- [45] J. Zhang, C. Y. Chung, and Y. Han, "A novel modal decomposition control and its application to PSS design for damping interarea oscillations in power systems," *IEEE Trans. Power Syst.*, vol. 27, no. 4, pp. 2015–2025, Nov. 2012.
- [46] P. Kundur, *Power System Stability and Control*. New York, NY, USA: McGraw-Hill, 1994.
- [47] Y. Chang and Z. Xu, "A novel SVC supplementary controller based on wide area signals," *Electric Power Syst. Res.*, vol. 77, no. 12, pp. 1569–1574, Oct. 2007.
- [48] M. M. Farsangi, Y. H. Song, and K. Y. Lee, "Choice of FACTS device control inputs for damping interarea oscillations," *IEEE Trans. Power Syst.*, vol. 19, no. 2, pp. 1135–1143, May 2004.

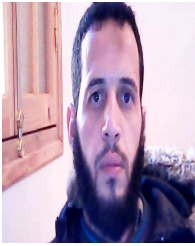

**MOKHTAR BENASLA** received the Ph.D. degree in electrical engineering from the University of Sidi Bel Abbas, Algeria, in 2018. He is currently an Assistant Professor with the Department of Electrical Engineering, Ibn Khaldoun University, Tiaret, Algeria. His research interests include power system dynamics and control, HVDC transmission systems, integration of renewable energy sources, and power system operation and planning.



**TAYEB ALLAOUJI** received the bachelor's (engineering) degree in electrical engineering from Ibn Khaldoun University, Tiaret, in 1996, and the master's degree from the University of Science and Technology of Oran, in 2002. He is a member of the Energetic Engineering and Computer Engineering Laboratory, Ibn Khaldoun University. His research interests include intelligent control of power systems and FACTS, active filter, and renewable energies.



**FELIX RAFAEL SEGUNDO SEVILLA** (Senior Member, IEEE) received the B.Sc. degree in electrical engineering from Instituto Tecnológico de Morelia, Mexico, in 2005, the M.Sc. degree in automatic control from Universidad Autónoma de Nuevo León (UANL), Mexico, in 2007, and the Ph.D. degree from Imperial College London, U.K., in 2013. From 2007 to 2008, he was with the Automation and Control Group, Corporate Research Centre of ABB, Switzerland. From January 2013 to July 2014, he was a Postdoctoral Research Fellow with the School of Electrical Engineering, KTH Royal Institute of Technology, Stockholm, Sweden. Since 2014, he has been a Research Associate with the Electric Power Systems and Smart Grids Group, Institute of Energy Systems and Fluid Engineering (IEFE), Zurich University of Applied Science (ZHAW), Winterthur, Switzerland.



**PETR KORBA** (Senior Member, IEEE) received the Dipl.-Ing. degree in electrical engineering from Czech Technical University, Prague, Czech Republic, in 1995, and the Dr.-Ing. degree from the University of Duisburg, Germany, in 1999. He was a member of Academic Staff with the Institute of Science and Technology, The University of Manchester, in 2001. He joined ABB Switzerland Ltd., where he held different positions in the business unit power system automation.

He was a Principal Scientist with ABB Corporate Research Ltd., for more than ten years. Since 2008, he has been a Lecturer with ETH Zurich. He was a Professor of electric power systems with the Zurich University of Applied Sciences, in 2012, where he is currently the Head of the Electric Power Systems Group and the Deputy Head of the Institute of Energy Systems and Fluid Engineering. He is also the Co-Director of the Swiss Competence Centre of Energy Research (SCCER, Grids, and Components).



**MOULOUD DENAÏ** received the degree in electrical engineering from the University of Science and Technology of Algiers and École Nationale Polytechnique of Algiers, Algeria, and the Ph.D. degree in control engineering from the University of Sheffield, U.K. He was with the University of Science and Technology of Oran, Algeria, until 2004, and the University of Sheffield, from 2004 to 2010. From 2010 to 2014, he was with the University of Teesside, U.K. He has been

with the University of Hertfordshire, U.K., since 2014. His research interests include energy, intelligent control design, computational intelligence applications to efficiency optimization in renewable energy systems, with a particular focus in the management of smart homes and dynamic scheduling, optimization and control of future smart grids, condition monitoring and asset management in electric power networks, energy storage systems integration into the grid, smart meter data analytics using machine learning techniques for efficient energy management, and electric vehicles integration into the distribution grid and V2G/G2V management.

...