

19



Europäisches Patentamt  
European Patent Office  
Office européen des brevets



11 Publication number:

**0 316 172 B1**

12

## EUROPEAN PATENT SPECIFICATION

45 Date of publication of patent specification: **29.07.92** 51 Int. Cl.<sup>5</sup>: **G01N 15/14, G01N 15/02**

21 Application number: **88310596.7**

22 Date of filing: **10.11.88**

Consolidated with 88909599.8/0386063  
(European application No./publication No.) by  
decision dated 09.04.91.

54 **Portable particle analysers.**

30 Priority: **10.11.87 GB 8726305**

43 Date of publication of application:  
**17.05.89 Bulletin 89/20**

45 Publication of the grant of the patent:  
**29.07.92 Bulletin 92/31**

84 Designated Contracting States:  
**AT BE CH DE ES FR GB GR IT LI LU NL SE**

56 References cited:  
**FR-A- 2 535 051**  
**GB-A- 2 041 516**  
**US-A- 4 200 802**

**AEROSOL MEASUREMENT**, editors **D.A. LUNDGREN** et al., 1979, pages 241-259, University Presses of Florida, Gainesville, US; **R.W. STOREY**: "Aerosol field measurements using light-scattering photometers"

73 Proprietor: **The Secretary of State for Defence in Her Britannic Majesty's Government of the United Kingdom of Great Britain and Northern Ireland Whitehall London SW1A 2HB(GB)**

72 Inventor: **Ludlow, Ian Keith Parkway Close Welwyn Garden City Hertfordshire(GB)**  
Inventor: **Kaye, Paul Henry 1 Coopers Close Kimpton Hertfordshire(GB)**

74 Representative: **Beckham, Robert William et al Procurement Executive Ministry of Defence Patents 1A(4), Room 2014 Empress State Building Lillie Road London SW6 1TR(GB)**

**EP 0 316 172 B1**

Note: Within nine months from the publication of the mention of the grant of the European patent, any person may give notice to the European Patent Office of opposition to the European patent granted. Notice of opposition shall be filed in a written reasoned statement. It shall not be deemed to have been filed until the opposition fee has been paid (Art. 99(1) European patent convention).

## Description

This invention relates to apparatus for the analysis of fluidborne particles. For examples, in the study of aerosols, aerosol dispersion and airborne particulate pollution control, there is a requirement for the rapid determination of particle size distribution especially in the diameter range 1 to 10 microns, together with some knowledge of the geometry and symmetry of individual particles. The latter information could, for example, enable particles with spherical symmetry to be identified and thus allow the counting/monitoring of liquid droplets in an environment including other solid, non-spherical particles. In the context of the present specification, the term particles is intended to apply both to solid bodies and to drops of liquid.

It is desirable for such apparatus to be able to count individual particles in a sample at rates of, typically, 20,000 particles per second, to be able to distinguish between spherical and non-spherical particles in the sample and to count each type. Another desirable feature is to categorise spherical particles having diameters of a few microns into a number of size ends and also in this connection to classify particle coincidences as 'non-spherical' and hence to ignore them in the compilation of size spectra based on the assumption the particle is spherical.

The normal techniques for the examination of particles, as used in several instruments available commercially, employ the detection and analysis of electromagnetic radiation scattered by the particles. All such instruments use a mechanical mechanism to drive the sample air through a "sensing volume" where the carried particles are illuminated by the incident electromagnetic radiation. The radiation scattered by the particles is received by one or more detectors which convert the energy to electrical signals from which information may be extracted by appropriate electrical circuits.

Particle analysers are known, for example, as described in UK Patent Application numbers 8619050, 2044951A and US Patent No 3946239. These all describe analysers which comprise a concave reflector in a scatter chamber, and a flow of sample fluid intercepted by a beam of radiation. The light scattered from individual particles in the fluid is directed by the reflector to radiation collectors and subsequently analysed. All of these, however, suffer from being cumbersome and fragile and consequently not readily portable. Moreover, light scattered at low angles from the particles in the sample is not detected by any of the above prior art systems.

Another analyser is described in UK Patent number 2041516 which discloses a particle an-

alyser of the type described above but which has an additional feature in that the concave reflector has a transparent window in it which is used to collect back scattered light by use of lenses and photomultipliers. The intensity of the back scattered light achieved by this apparatus is very low and passes through collimation means before being collected by photomultipliers. This means that not all back scattered radiation will be detected and the apparatus required to collect the light is complex, cumbersome and relatively expensive. Moreover, the apparatus is not portable.

There is therefore a need for a particle analyser which is portable compact and relatively inexpensive and determines the size, geometry and number of particles in a sample fluid, and is additionally capable of effectively and efficiently detecting and analysing light scattered at low angles from the individual particles in the sample.

According to one aspect of the present invention a particle analyser includes a first scatter chamber, means for providing a sample of fluid in the form of a laminar flow through the first scatter chamber, a beam of radiation, adapted to intercept the sample at right angles to a direction of flow of the sample at a focal point of a first concave reflector, the first concave reflector being used to direct the radiation scattered by individual particles in the sample towards at least one first reflector radiation collector, means for converting the radiation collected into electrical signals for processing and analysis, and means for dumping the non-scattered radiation characterised in that an aperture in the first concave reflector leads to a second scatter chamber comprising a second concave reflector with a second reflector radiation collector located at its near focal point and positioned so that its far focal point is at the point of interception of the beam of radiation and the sample, the second reflector radiation collector being connected to means for converting the radiation collected into electrical signals for processing and analysis.

The beam of radiation may be provided by a laser which may be mounted in any one of a number of ways so that the beam intercepts the sample flow at right angles. For example, it may be mounted aligned with the principal axis of the first concave reflector; such an arrangement would make the apparatus more rugged and compact.

The first concave reflector may be a parabolic mirror, or, alternatively may be an ellipsoid mirror, which would reflect the scattered light to a single point of detection.

The advantage of having a second chamber mounted coaxially with the first chamber is so that light scattered at low angles from the individual particles in the sample can be detected and analysed also. This information is particularly useful

in determining the size of particles. The second chamber also includes a second concave reflector. The second concave reflector is preferably an ellipsoid mirror and has a radiation collector located at a near focal point and a far focal point at the point of interception of the beam and sample. Thus, light scattered at low angles is reflected by the ellipsoid mirror to the near focal point and collected by the radiation collector there. Radiation collectors of any suitable type may be used in the present invention and may include photomultiplier units, optical fibre leading to such units or lenses directing the radiation to a photomultiplier unit or optical fibre.

According to a second aspect of the present invention a method of particle analysis includes the steps of:

passing a sample of fluid in the form of a laminar flow through a first scatter chamber;

passing a beam of radiation through the first scatter chamber so as to intercept the sample at right angles to a direction of flow at a focal point of a first concave reflector, the first concave reflector being used to direct the radiation towards at least one first reflector radiation collector; allowing low angle scattered radiation to pass through an aperture in the first concave reflector into a second chamber which includes a second concave reflector and a second reflector radiation collector located at the near focal point of the second concave reflector the second concave reflector being positioned so that its far focal point is at the point of interception of the beam of radiation and the sample; and converting the radiation collected into electrical signals, processing and analysing the electrical signals, and dumping the non-scattered radiation

The sample may be an aerosol.

A number of embodiments of the invention will now be described by way of example only, with reference to the accompanying drawings, in which:

Fig 1 is a side view in section of a preferred embodiment of the invention;

Fig 1a is a view along the line in fig 1;

Fig 2 is a side view in section of another embodiment of the invention;

As shown in Fig 1a first scatter chamber 10 includes a first concave reflector in the form of a parabolic mirror 11, lenses 12, and first reflector radiation collectors 13. A laser 14 is mounted aligned with the principal axis of the parabolic mirror 11 and directs a beam 15 of radiation towards the focal point 16 of the parabolic mirror 11 where it intercepts with the sample fluid 17 in the form of a laminar flow. An aperture 18 leads to a second chamber 19 which includes a second concave reflector in the form of an ellipsoid reflector 20 and a second reflector radiation collector 21 located at the near focal point of the ellipsoid

reflector 20 and the ellipsoid reflector is positioned so that its far focal point is situated at the focal point 16 of the first parabolic reflector 11. A beam dump 22, typically a Rayleigh horn, is located at an aperture in the ellipsoid mirror 20 to collect the non-scattered radiation. Radiation collectors 13 and 21 are connected to photomultiplier tubes 23. Fig 1a shows a possible arrangement of radiation collectors 13 around the laser 14. Although only three collectors are shown here, any number of detectors may be located radially around the laser 14.

Another embodiment of the invention is shown in Fig 2. In this embodiment both the first reflector 50 and the second reflector 51 are ellipsoid mirrors. In this, the laser 14 is at an angle of  $90^\circ$  to the principal axes of the reflectors, so that mirror 41 directs the beam 15 along the principal axis. The sample 17 is directed at right angles to the laser beam 15 and intercepts it at the near focal point 16 of the first ellipsoid reflector 50. The second ellipsoid reflector 51 is positioned so that its far focal point coincides with point 16. Photomultiplier tubes 23 are located at the far focal point of the first ellipsoid reflector 11 and at the near focal point of the second ellipsoid reflector 20 to collect the scattered radiation. The beam dump 22 is located within the second scatter chamber 19 to dump the non-scattered radiation.

The radiation collector 23 in Fig 2 is positioned to face the aperture 18 in the first chamber 10 as opposed to being placed at  $90^\circ$  to this direction as shown in Fig 1. The latter arrangement would collect relatively more radiation of low angle deflection, but less overall since only deflections in the direction of the face of the collector will be recorded.

In use, the sample of fluid 17 is supplied in laminar flow by means of a sheath of constant velocity air being supplied around the sample, as shown in Figs 1 and 2. This is so that the outer parts of the sample flow have the same velocity as the inner parts. The outer parts of the sample would otherwise flow more slowly due to friction with stationary air next to the sample flow. Additionally, a coaxial tube supplying the sheath of air is designed to dynamically focus particles in the sample to provide a laminar flow of particles. The laser beam 15 intercepts at right angles the flow of fluid 17 and light is scattered from the individual particles contained in the fluid. The scattered radiation reflects off the walls of the first concave reflector in the first scatter chamber 10. If the first concave reflector is a parabolic mirror 11 (Fig 1) the radiation is reflected parallel to its principal axis or if it is an ellipsoid mirror 40 and 50 (in Fig 2), the radiation is directed to the far focal point of the mirror. This deflected radiation is then directed towards photomultiplier tubes 23 either directly, as

in Fig 2, or by using lenses 12 as in Fig 1 to direct the radiation towards the photomultiplier units 23.

Radiation scattered at low angles by the particles is collected in the second chamber 19, which may include an ellipsoid mirror 20 and 51 in Figs 1 and 2 and radiation collectors which may be a photomultiplier tube 23 as in Fig 2 or a lens 21 Fig 1 leading to such a tube 23.

All the radiation collected is then converted into electrical signals, processed and analysed, and the information may be extracted by appropriate electronic circuits.

Although this invention has been described by way of example and with reference to possible embodiments thereof, it is to be understood that modifications or improvements may be made without departing from the scope of the invention as defined in the appended claims.

### Claims

1. A particle analyser including a first scatter chamber (10), means for providing a sample of fluid (17) in the form Of a laminar flow through the first scatter chamber (10), a beam of radiation (15), adapted to intercept the sample (17) at right angles to a direction of flow at a focal point (16) of a first concave reflector (11), the first concave reflector (11) being used to direct the radiation scattered by individual particles in the sample towards at least one first reflector radiation collector (13), means (23) for converting the radiation collected into electrical signals for processing and analysis, and means (22) for dumping the non-scattered radiation characterised in that an aperture (18) in the first concave reflector (11) leads to a second scatter chamber (19) comprising a second concave reflector (20) with a second reflector radiation collector (21) located at its near focal point and positioned so that its far focal point is at the point of interception of the beam of radiation and the sample, the second reflector radiation collector (21) being connected to means (23) for converting the radiation collected into electrical signals for processing and analysis.
2. A particle analyser as claimed in Claim 1 characterised in that the beam of radiation is supplied by a laser (14).
3. A particle analyser as claimed in Claim 2 characterised in that the laser (14) is mounted on and aligned with the principal axis of the first concave reflector (11).
4. A particle analyser as claimed in Claim 1 or Claim 2 characterised in that a small reflector (41) is mounted on the principal axis of the concave reflector (11) to reflect the beam from a laser (14) mounted at an angle to the principal axis.
5. A particle analyser as claimed in Claim 4 characterised in that the angle is 90° degrees.
6. A particle analyser as claimed in any previous Claim characterised in that the first concave reflector (11) is a parabolic reflector.
7. A particle analyser as claimed in Claims 1 to 5 characterised in that the first concave reflector (11) is an ellipsoid with the point of interception at the proximal focal point, and a radiation collector (13) at or near the distal focal point.
8. A particle analyser as claimed in Claim 1 characterised in that the second concave reflector (20) is an ellipsoidal reflector.
9. A particle analyser as claimed in any previous Claim characterised in that each radiation collector (13, 21) is a photomultiplier unit (23).
10. A particle analyser as claimed in any one of Claims 1 to 9 characterised in that each radiation collector (13, 21) has an optical fibre leading to a photomultiplier unit (23).
11. A particle analyser as claimed in any one of Claims 1 to 9 characterised in that each radiation collector (13, 21) is a lens directing the radiation up to a photomultiplier unit (23) or an optical fibre.
12. A method of particle analysis including the steps of: passing a sample of fluid (17) in the form of a laminar flow through a first scatter chamber (10); passing a beam of radiation (15) through the first scatter chamber (10) so as to intercept the sample (17) at right angles to a direction of flow at a focal point (16) of a first concave reflector (11), the first concave reflector (11) being used to direct the radiation towards at least one first reflector radiation collector 13; allowing low angle scattered radiation to pass through an aperture (18) in the first concave reflector (11) into a second chamber (19) which includes a second concave reflector (20) and a second reflector radiation collector (21) located at the near focal point of the second concave reflector (20) the second concave reflector (20) being positioned so that its far focal point is at the point of interception of the beam of radiation (15) and the sample

(17); and converting the radiation collected into electrical signals (23), processing and analysing the electrical signals, and dumping the non-scattered radiation (23).

13. A method of particle analysis as claimed in Claim 13 characterised in that the sample (17) is an aerosol.

#### Revendications

1. Analyseur de particules comprenant une première chambre (10) de diffusion, un dispositif destiné à former un échantillon de fluide (17) sous forme d'un courant laminaire circulant dans la première chambre (10) de diffusion, un faisceau d'un rayonnement (15) destiné à intercepter l'échantillon (17) perpendiculairement à la direction d'écoulement à un point focal (16) d'un premier réflecteur concave (11), le premier réflecteur concave (11) étant utilisé afin qu'il dirige le rayonnement diffusé par les particules individuelles de l'échantillon vers au moins un premier collecteur de rayonnement à réflecteur (13), un dispositif (23) destiné à transformer le rayonnement collecté en signaux électriques qui peuvent être traités et analysés, et un dispositif (22) destiné à absorber le rayonnement non diffusé, caractérisé en ce qu'une ouverture (18) du premier réflecteur concave (11) conduit à une seconde chambre (19) de diffusion qui comporte un second réflecteur concave (20), un second collecteur de rayonnement à réflecteur (21) étant placé près de son point focal proche et étant disposé de manière que son point focal lointain se trouve au point d'interception du faisceau du rayonnement et de l'échantillon, le second collecteur de rayonnement à réflecteur (21) étant connecté au dispositif (23) de transformation du rayonnement collecté en signaux électriques destinés à être traités et analysés.
2. Analyseur de particules selon la revendication 1, caractérisé en ce que le faisceau du rayonnement est transmis par un laser (14).
3. Analyseur de particules selon la revendication 2, caractérisé en ce que le laser (14) est monté sur l'axe principal du premier réflecteur concave (11) et est aligné sur cet axe.
4. Analyseur de particules selon la revendication 1 ou 2, caractérisé en ce qu'un petit réflecteur (41) est monté sur l'axe principal du réflecteur concave (11) afin qu'il réfléchisse le faisceau d'un laser (14) monté suivant un certain angle par rapport à l'axe principal.

5. Analyseur de particules selon la revendication 4, caractérisé en ce que l'angle est égal à  $90^\circ$ .

6. Analyseur de particules selon l'une quelconque des revendications précédentes, caractérisé en ce que le premier réflecteur concave (11) est un réflecteur parabolique.

7. Analyseur de particules selon les revendications 1 à 5, caractérisé en ce que le premier réflecteur concave (11) est un ellipsoïde, le point d'interception se trouvant au point local proche, et un collecteur de rayonnement (13) se trouvant au point local lointain ou à son voisinage.

8. Analyseur de particules selon la revendication 1, caractérisé en ce que le second réflecteur concave (20) est un réflecteur ellipsoïdal.

9. Analyseur de particules selon l'une quelconque des revendications précédentes, caractérisé en ce que chaque collecteur d'un rayonnement (13, 21) est un ensemble photomultiplicateur (23).

10. Analyseur de particules selon l'une quelconque des revendications 1 à 9, caractérisé en ce que chaque collecteur de rayonnement (13, 21) possède une libre optique conduisant à un ensemble photomultiplicateur (23).

11. Analyseur de particules selon l'une quelconque des revendications 1 à 9, caractérisé en ce que chaque collecteur d'un rayonnement (13, 21) est une lentille qui dirige le rayonnement sur un ensemble photomultiplicateur (23) ou une libre optique.

12. Procédé d'analyse de particules, comprenant les étapes suivantes : la circulation d'un échantillon de fluide (17) sous forme d'un courant laminaire dans une première chambre de diffusion (10), la circulation d'un faisceau d'un rayonnement (15) dans la première chambre de diffusion (10) afin qu'il intercepte l'échantillon (17) en direction perpendiculaire à la direction d'écoulement, à un point local (16) d'un premier réflecteur concave (11), le premier réflecteur concave (11) étant utilisé afin qu'il dirige le rayonnement vers au moins un premier collecteur de rayonnement à réflecteur (13), le passage du rayonnement diffusé suivant de petits angles par une ouverture (18) formée dans le premier réflecteur concave (11) vers une seconde chambre (19) qui comporte un second réflecteur concave (20) et un se-

cond collecteur de rayonnement à réflecteur (21) placé au point focal proche du second réflecteur concave (20), le second réflecteur concave (20) étant disposé de manière que son point focal lointain se trouve au point d'interception du faisceau du rayonnement (15) et de l'échantillon (17), et la transformation du rayonnement collecté en signaux électriques (23), le traitement et l'analyse des signaux électriques, et l'absorption du rayonnement non diffusé (23).

13. Procédé d'analyse de particules selon la revendication 12, caractérisé en ce que l'échantillon (17) est un aérosol.

### Patentansprüche

1. Partikelanalyisiervorrichtung mit einer ersten Streukammer (10), Mitteln zum Erzeugen einer laminaren Strömung von Probefluid (17) durch die erste Streukammer (10), einem Strahl (15), der die Probe (17) in rechten Winkeln zu einer Strömungsrichtung an einem Brennpunkt (16) eines ersten konkaven Reflektors (11) schneidet, wobei der erste konkave Reflektor (11) die durch Einzelpartikel der Probe gestreute Strahlung in Richtung zumindest eines ersten Strahlungskollektors (13) für reflektierte Strahlung richtet, Mitteln (23) zum Umwandeln der gesammelten Strahlung, für eine Weiterverarbeitung und zur Analyse, in elektrische Signale und Mitteln (22) zum Auffangen der nichtgestreuten Strahlung, **dadurch gekennzeichnet, daß** eine Öffnung (18) im ersten konkaven Reflektor zu einer zweiten Streukammer (19) führt, mit einem zweiten konkaven Reflektor (20) mit einem zweiten Strahlungskollektor (21) für reflektierte Strahlung, der an seinem Nahbrennpunkt angeordnet ist und der derart positioniert ist, daß sein Fernbrennpunkt im Schnittpunkt des Strahls und der Probe liegt, wobei der zweite Strahlungskollektor (21) für reflektierte Strahlung mit Mitteln (23) in Verbindung steht, zum Umwandeln der gesammelten Strahlung in elektrische Signale, für eine Weiterverarbeitung und zur Analyse.
2. Partikelanalyisiervorrichtung nach Anspruch 1, dadurch gekennzeichnet, daß der Strahl von einem Laser (14) erzeugt wird.
3. Partikelanalyisiervorrichtung nach Anspruch 2, dadurch gekennzeichnet, daß der Laser (14) an der Hauptachse des ersten konkaven Reflektors (11) montiert und daaus ausgerichtet ist.
4. Partikelanalyisiervorrichtung nach Anspruch 1 oder 2, dadurch gekennzeichnet, daß ein kleiner Reflektor (41) auf der Hauptachse des konkaven Reflektors (11) montiert ist, zum Reflektieren des Strahls eines Lasers (14), der mit einem Winkel zur Hauptachse angeordnet ist.
5. Partikelanalyisiervorrichtung nach Anspruch 4, dadurch gekennzeichnet, daß der Winkel 90 ° beträgt.
6. Partikelanalyisiervorrichtung nach einem der vorangehenden Ansprüche, dadurch gekennzeichnet, daß der erste konkave Reflektor (11) ein Parabolreflektor ist.
7. Partikelanalyisiervorrichtung nach Anspruch 1 bis 5, dadurch gekennzeichnet, daß der erste konkave Reflektor (11) ein Ellipsoid ist, mit einem Schnittpunkt am proximalen Brennpunkt, und einem Strahlungskollektor (13) an oder nahe dem distalen Brennpunkt.
8. Partikelanalyisiervorrichtung nach Anspruch 1, dadurch gekennzeichnet, daß der zweite konkave Reflektor (20) ein ellipsoider Reflektor ist.
9. Partikelanalyisiervorrichtung nach einem der vorangehenden Ansprüche, dadurch gekennzeichnet, daß jeder Strahlungskollektor (13, 21) eine Photoelektronen-Vervielfachereinheit (23) ist.
10. Partikelanalyisiervorrichtung nach einem der Ansprüche 1 bis 9, dadurch gekennzeichnet, daß jeder Strahlungskollektor (13, 21) ein optisches Kabel aufweist, das zu einer Photoelektronen-Vervielfachereinheit (23) führt.
11. Partikelanalyisiervorrichtung nach einem der Ansprüche 1 bis 9, dadurch gekennzeichnet, daß jeder Strahlungskollektor (13, 21) eine Linse ist, die die Strahlung auf eine Photoelektronen-Vervielfachereinheit (23) oder ein optisches Kabel richtet.
12. Verfahren zur Partikelanalyse, mit folgenden Schritten:
  - Führen einer Fluidprobe (17) in der Form eines laminaren Fluidstroms durch eine erste Streukammer (10),
  - Führen eines Strahls (15) durch die erste Streukammer (10), so daß dieser die Probe (17) mit rechten Winkeln zur Strömungsrichtung an einem Brennpunkt (16) eines ersten konkaven Reflektors (11) schneidet, wobei der erste konkave Reflektor (11) die Strahlung in Richtung zu-

mindest eines ersten Strahlungskollektors (13) für reflektierte Strahlung richtet, so daß die mit einem kleinen Winkel gestreute Strahlung durch eine Öffnung (18) im ersten konkaven Reflektor (11) in eine zweite Kammer (19) geleitet werden kann, die einen zweiten konkaven Reflektor (20) und einen zweiten Strahlungskollektor (21) für reflektierte Strahlung enthält, der am Nahbrennpunkt des zweiten konkaven Reflektors (20) angeordnet ist, wobei der zweite konkave Reflektor (20) so angeordnet ist, daß sein Fernbrennpunkt am Schnittpunkt des Strahls (15) und der Probe (17) liegt, und

- Konvertieren der gesammelten Strahlung in elektrische Signale (23), Verarbeiten und Analysieren der elektrischen Signale, und Auffangen der nichtgestreuten Strahlung (23).

**13.** Verfahren zur Partikelanalyse nach Anspruch 13, dadurch gekennzeichnet, daß die Probe (17) ein Aerosol ist.

5

10

15

20

25

30

35

40

45

50

55

7

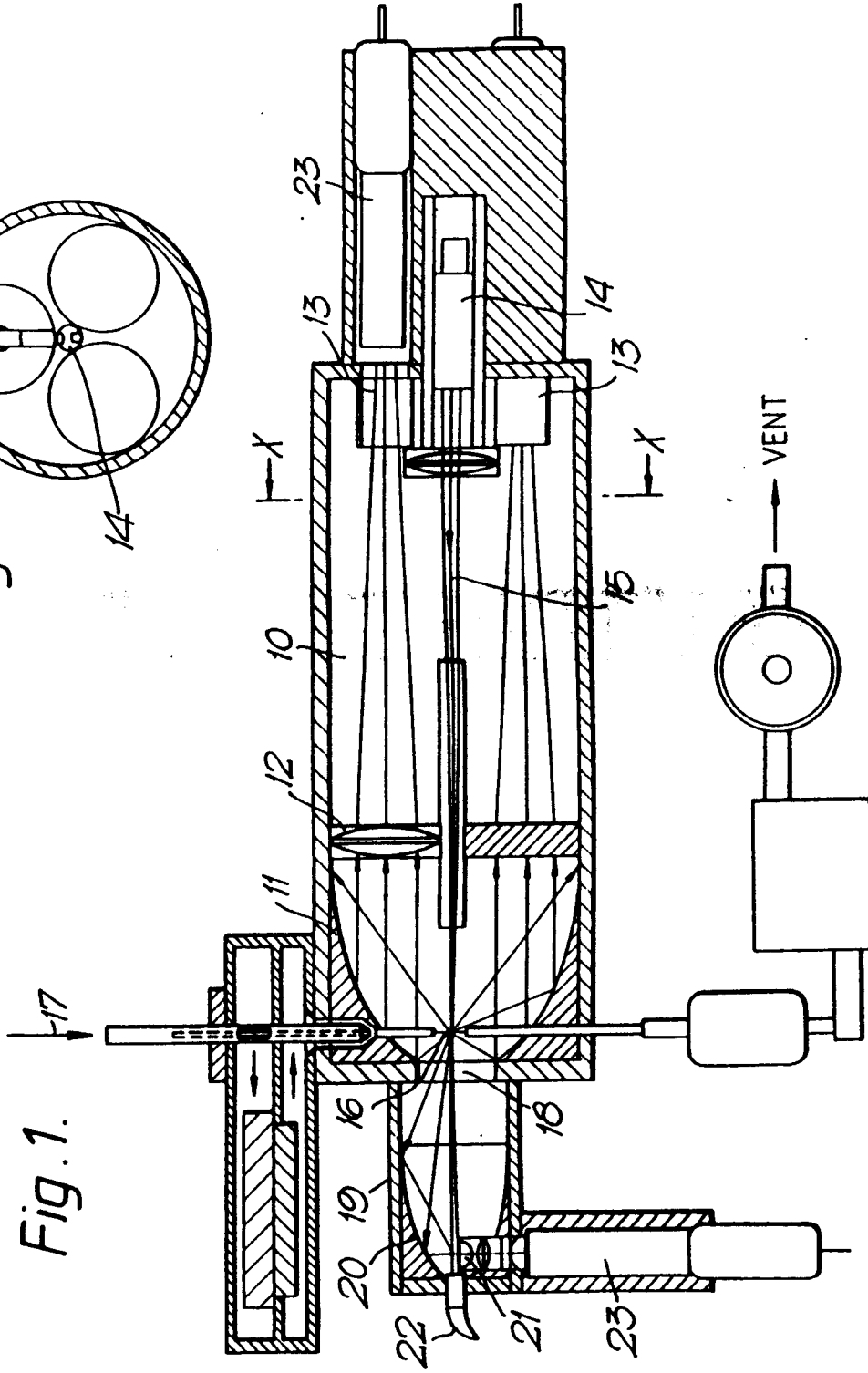
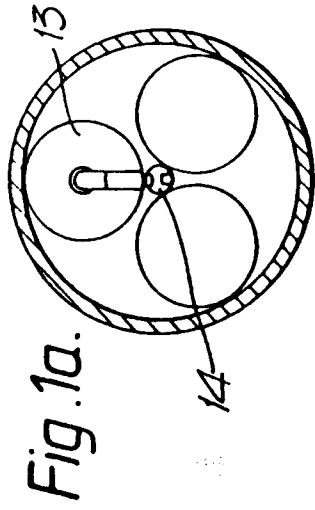



Fig. 2

