

Power Quality Enhancement of DFIG Based Wind Energy System Using Priority Control Strategies

A. BOUZEKRI T. ALLAOUI

Laboratory of Electrical and Computer Engineering (L2GEGI), Ibn Khaldun University, Tiaret, Algeria
bouzekriamina@hotmail.fr , allaoui_tb@yahoo.fr

M. DENAI

School of Engineering and Technology, University of Hertfordshire, Hatfield, United Kingdom

Abstract: *The integration of intermittent renewable energy sources into the electric grid presents some challenges in terms of power quality issues, voltage regulation and stability. Power quality relates to those factors which affect the variability of the voltage level and distortion of the voltage and current waveforms which can cause severe adverse effects to the electric grid. The paper focuses on the design and evaluation of a priority control strategy for improving the quality of energy of a grid-connected variable speed Doubly Fed Induction Generator (DFIG) wind energy conversion system. The aim of priority control is to manage the priority among three different controls: active stator power control; reactive stator power control and harmonic rotor current control by using the active shunt filter with SRF method harmonic compensation, and to have a high performance and robustness; an adaptive-fuzzy PI control are including for currents rotor control.*

The simulation model was developed in Matlab/Simulink environment. The results show that the proposed control scheme can effectively reduce the Total Harmonic Distortion (THD) in the grid currents.

Key words: *Active power filters (APF), Doubly-Fed Induction Generator (DFIG), PI fuzzy adaptive controller, priority method control, Variable-Speed Wind Turbines (VSWT), Shunt Active power filter (SAPF).*

1. Introduction

Wind energy is rapidly developing as one of the most prominent renewable energy source in the world. By the end of 2020, it is expected that wind power generation will increase to 1.26 million of MW which will be sufficient to cover 12% of the world's electricity consumption [1].

Various wind turbine configurations using different generator topologies have been extensively studied, developed and built. There are two main types of wind turbines systems: the Fixed-Speed Wind Turbine (FSWT) and the Variable-Speed Wind Turbine (VSWT). The FSWT uses a multistage gearbox and a squirrel cage induction generator (SCIG) and is directly connected to the grid. The FSWT uses a multistage gearbox and a Doubly-Fed Induction Generator (DFIG) and is connected to the grid via a power electronic converter. VSWT has become the most popular type of wind turbine system because it uses a power converter which offers better control capability than FSWT [2, 3].

With the integration of large scale wind farms into the grid, power quality issues arise such as voltage fluctuation, poor power factor and harmonic distortion. Increased harmonic levels are mainly due to nonlinear loads and the increased use nonlinear devices such as power electronic converters to interface renewable energy sources to the distribution grid. Producing harmonics currents at the point of common coupling (PCC), has a number of undesirable effects which can adversely impact on the performance and reliability of the distribution grid. Therefore, the objective of the electric utility is to maintain good power quality and supply its customers with electric power in the form sinusoidal voltages and currents with appropriate magnitudes and frequency [4, 5].

The Conventional solutions used for a long time to mitigate harmonic distortion problems consisted of installing different types of passive filters at the PCC of major distorting loads. These Passive filters use inductive impedance and a capacitive impedance to achieve filtering capabilities. The addition of passive "LC" filters alters, or interferes, with the system impedance, and is known to cause resonance with other network impedances and can result in an excessive amplification of harmonics rather than harmonic reduction [6, 7].

Active power filters have shown to be an interesting alternative to compensate power distribution systems. Series and shunt topologies have already been presented and discussed in the technical literature. Shunt active power filters are more suitable to compensate current harmonic components and displacement power factor, while series topologies present better characteristics to compensate voltage distortions, [8].

The performance of shunt power active filters depends on the type of control method using. One of the time-domain control methods is the instantaneous active-reactive power theory (p-q theory). Other methods are using such as FFT (fast Fourier technique) technique, neural network, instantaneous p-q theory (instantaneous reactive power theory), synchronous d-q reference frame theory or by using suitable analog or digital electronic filters [9, 10].

In this paper we were used a new method

control called priority method control algorithm. It has been developed in order to improve the quality of energy in the grid over DFIG-based wind power system. Through this method; we were including an Active Power Filter (APF) in the stator powers control; which permits to manage the control between the stator powers and the harmonic current control. In addition of this method, we use too an intelligent method control which is the fuzzy approach. It is a convenient method to design a controller with a desired nonlinear dependence between the input and the output of the controller [11, 17]; so, we change the conventional controllers with adaptive fuzzy PI controllers to control the rotor currents and obtained the best robustness for a system.

The paper is organized as follows: in section 1, we describe the system studying with its control blocks, Rotor-Side Converter control, Grid-Side Converter control and MPPT control, and present there simulation results with harmonic waveform currents problem in section 3. In section 4 we explain the modified Rotor-Side Converter modeling, and carefully detail the priority method control with here algorithm and illustrate the APF control then the adaptive PI-fuzzy controller for the rotor currents control. In section 5, we show the simulation results of modified control and there harmonic currents waveform and compare them with the precedent one. In the final section, we draw the conclusion of the paper.

2. DFIG-Based Wind Power System Model

The proposed circuit shown in Fig. 1 consists of a wind turbine connected to a DFIG. The DFIG is simulated as an induction machine having 3-phase supply in the stator and 3-phase supply in the rotor. The rotor coupled via two powers converters: the rotor-side converter (RSC) and the grid-side converter (GSC). The RSC ensures a decoupled active and reactive stator power control, P and Q according to the reference torque delivered by the maximum power point tracking control (MPPT). The GRC controls the power flow exchange with the grid via the rotor, by maintaining the DC bus at a constant voltage level.

2.1 Maximum power point tracking (MPPT) of a VSWT

Due to the intermittent and variable nature of wind power, it is desirable to determine the optimal generator speed which extracts the maximum power from the turbine. MPPT allows variable-speed wind turbine to operate at an optimal rotation speed as a function of wind speed and capture the maximum power from the available wind energy. Many different MPPT control strategies have been proposed in the literature [13, 14]. The MPPT method used in this paper is termed Tip Speed Rotor

(TSR) control [15]. This method regulates the rational speed of the generator in order to maintain the TSR to an optimal value at which the power extracted is maximum. It requires both the wind speed and the turbine speed to be measured or estimated in addition to the knowledge of the optimal TSR of the turbine in order to be able extract maximum possible power. Fig. 2 shows the block diagram of a MPPT control with TSR control.

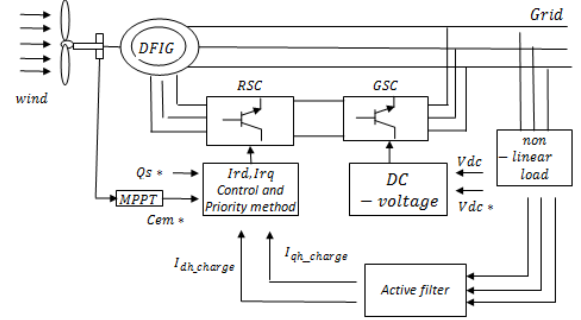

Fig. 1. Block diagram of the wind power system based in DFIG.

Where R is the radius of wind turbine, λ_{opt} is the optimal TSR of the turbine and G is the inverted gain of the reducer.

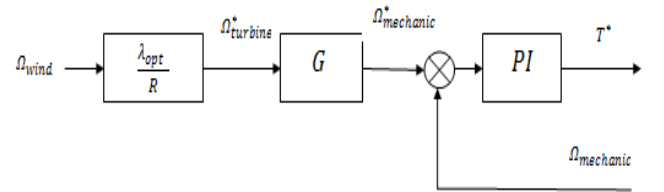

Fig. 2. MPPT control.

Where R is the radius of wind turbine, λ_{opt} is the optimal TSR of the turbine and G is the inverted gain of the reducer.

2.2.1 PI control regulator

The transfer function relating the mechanical speed and the electromagnetic torque is:

$$G_{MPPT}(s) = \frac{1}{Js + F} \quad (1)$$

Where J and F represent the inertia and friction coefficient of the overall respectively.

The transfer function of the speed control loop can be calculated as:

$$G_{MPPT}(s)_{fb} = \frac{K_{p\Omega} \left(s + \frac{K_{i\Omega}}{K_{p\Omega}} \right) / J}{s^2 + \left(\frac{F + K_{p\Omega}}{J} \right) s + \frac{K_{i\Omega}}{J}} \quad (2)$$

2.2. Rotor-Side Converter Control (RSC)

The DFIG connected directly to the network through the stator, and controlled by its rotor through an ideal ac/ac direct converter. To control the power exchanged between the stator and the network, one uses the vector control with direct stator flux [5, 2, 16].

Fig. 3 shows a schematic block diagram of the RSC control.

The active and reactive stator powers and the electromagnetic torque of the DFIG in the Park frame are written as follows [4, 5]:

$$P_s = -V_{sq} \frac{M_{sr}}{L_s} I_{rq} \quad (3)$$

$$Q_s = V_{sq} \frac{\varphi_{sd}}{L_s} - V_{sq} \frac{M_{sr}}{L_s} I_{rd} \quad (4)$$

$$T = -p \frac{M_{sr}}{L_s} \varphi_{sd} I_{rq} \quad (5)$$

Where M_{sr} , L_s and p are respectively the main inductance and the inductance of the stator and number of pair poles.

Equations (3) and (4) show that the stator powers can be controlled via the rotor currents. There transfer function is shown as:

$$G_{I_{rd,q}}(s) = \frac{1}{\sigma L_r s + R_r} \quad (6)$$

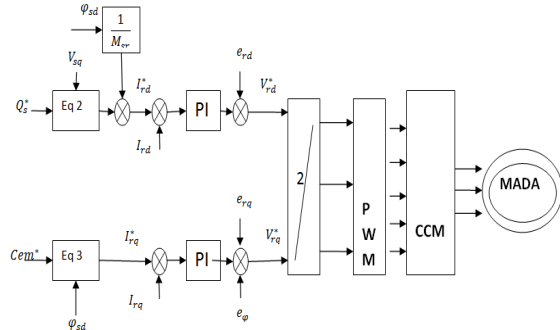

Fig. 3. Block diagram for the RSC control.

In order to gain a high performance, we can decouple the I_{rd} and I_{rq} by adding the e_{rq} term to output signal of the d-axis current controller, and e_{rd} and e_φ to the output signal of the q-axis current controller [6], [22].

Where;

$$\begin{cases} e_{rd} = -\sigma L_r \omega_r I_{rq} \\ e_{rq} = \sigma L_r \omega_r I_{rd} \\ e_\varphi = \omega_r \frac{M_{sr}}{L_s} \varphi_{sd} \end{cases} \quad (7)$$

2.3. Control of Grid-Side Converter (GSC)

The GSC is connected between the grid via RL filter and the DC-link. The role of this converter is to maintain the DC-link voltage as the constant value [2, 16]. The control of this voltage is achieved by the control of the rectifier currents as shown in the Fig. 4.

The DC-voltage signal V_{dc} is compared to its reference signal V_{dc}^* and the error signal from inputs to the proportional-integral (PI) regulator which generates the reference amplitude current I_{max} . This amplitude multiples with a three phases sinusoidal functions have a same input voltage frequency and compared with measurements grid currents to generate the switching pulse for the converter through the PWM block.

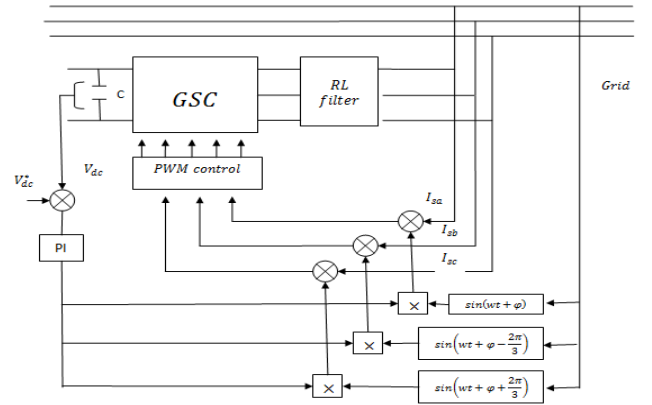

Fig. 4. Block diagram for the GSC control.

3. Simulation results

Simulation results were performed using software Matlab/Simulink. For these simulations, we consider that the wind system is steady and working in the zone of optimal functioning. The DFIG is rated at 2 MW and its parameters are given in the table below (Table 1), we also use a simple non-linear load which consists with an uncontrolled rectifier and RL load, in order to study the harmonic current in the grid, its parameters are shown in the same table.

Table 1
System parameters

Rated power	7.5 MW	Turbine power	10 MW
Stator voltage	220 V	Radius pale	3 m
Stator/rotor turns Ratio	1	Reducer gain G	5.4
R _s	0.455 ohm	Lf filter	0.014 H
R _r	0.62 ohm	Rf filter	0.3 ohm

Ls	0.084 H	C filter	2 mF
Lr	0.081 H	DCLink Voltage	800
Msr	0.078 H	Switching Frequency Fs	10 KHz
Lumped inertia constant	0.3125	RI load charge	4 ohm
Number of pole pairs	2	LI load charge	0.04 mH

The simulations results are presented in the Fig. 7. Fig. 7a shows the wind speed profile applied to the wind turbine blades with an average value of 7 m/s, which corresponds to the speed of DFIG under MPPT control as shown Fig. 7b. Fig. 7c shows real and reactive powers Qs, Ps of the supply.

At time $t = 0s$ the wind power system operates as a unity power factor and the reactive power equals zero. At time $t = 1s$, the stator reactive power reference is set to 500VAR. The corresponding changes in the reference direct rotor current are shown Fig. 7d. The DC link voltage is perfectly regulated to 700V (Fig. 7f).

Fig. 8 shows the non-linear load, generator and grid currents waveforms with FFT (Fast Fourier Transform) of both currents. The THD (Total Harmonic Distortion) of the load, generator and grid currents are equal to 31%, 0.20% and 8.29% respectively. For this augmentation of harmonic currents in grid, an active filter is used in the control system in order to reduce the THD created by the non-linearload.

4 Modified Rotor-Side Converter Control (RSC)

In order to improve the power quality at the point of common coupling (PCC) and reduce the harmonic currents in the grid, a new control strategy termed priority control method is proposed in the rotor-side converter control as shown Fig. 7. For that the precedent control block of RSC is modified to include the priority control algorithm. This control method permits to manage the priority between the following three different controls in descending order:

- Electromagnetic torque control which allows in turn to control the active stator power (first priority).
- Reactive power control to ensure the unity power factor (second priority).
- Harmonic rotor currents control for the active filter.

Where, the references rotor currents are input to the priority control block with the injected harmonic currents which come from APF block and the algorithm of this control manage the precedent three

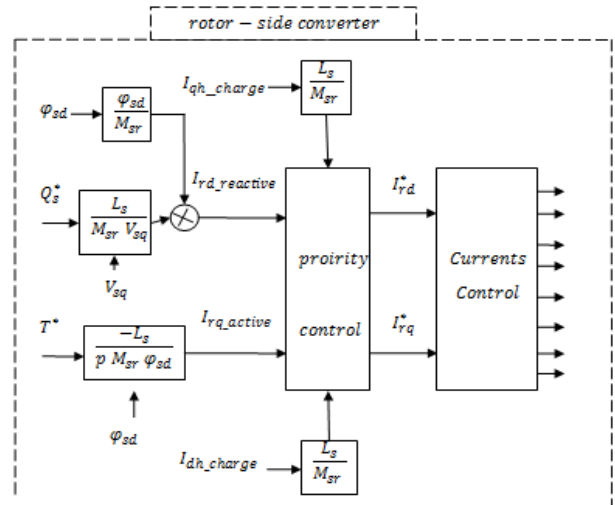

Fig. 5. Modified Rotor-Side Converter Control (MRSC).

priorities (control of stator power and injected of harmonic currents in the same time), and impose a new references rotor currents which are regulated later with adaptive PI-fuzzy controllers.

4.1 Active power filter

The operation principle of active filters is based on the injection of the harmonics required by the load; the filter generates a current equal and of opposite polarity to the harmonics currents drawn by the load and injects them into the grid [6].

The Synchronous Reference Frame (SRF) method can be used to extract the harmonic current contained in the grid. As shown in Fig. 6, the distorted currents are first transformed into two-phase stationary coordinates using α - β and d-q transformations and then a low pass filter (LPF) is applied to separate the harmonics from the fundamentals of the load currents [9]; it's transfer function is show as below:

$$FT_{lp}(f) = \frac{1}{1 + j(\frac{f}{f_c})} \quad (8)$$

Where f is the grid frequency and f_c is the cutoff frequency which equal 1kHz.

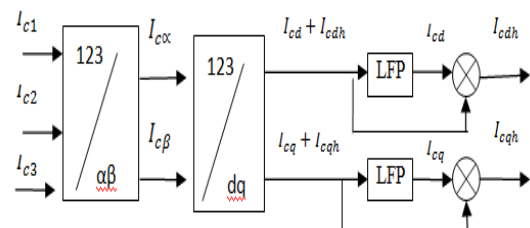
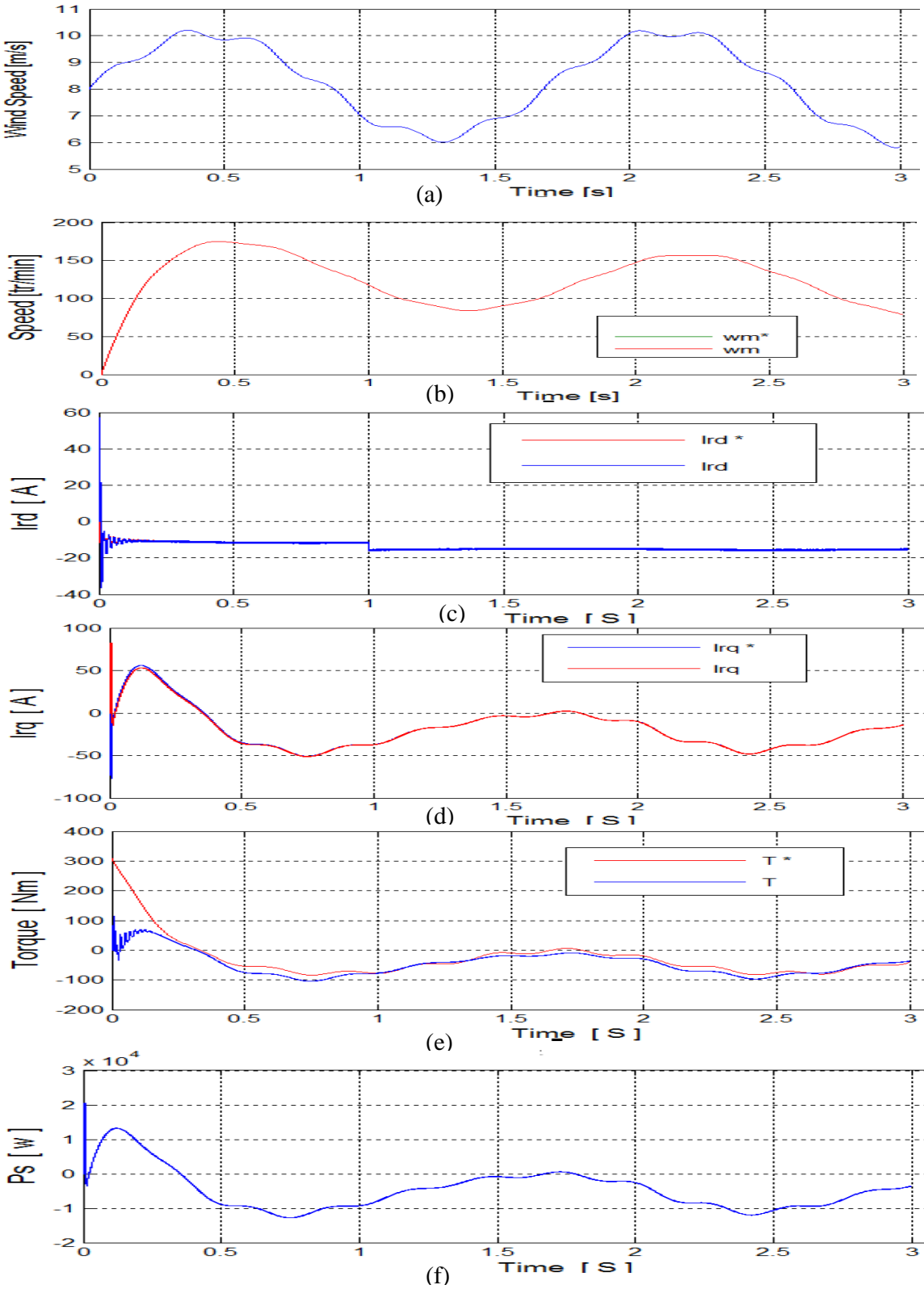

Fig. 6. Block diagram of SRF method.



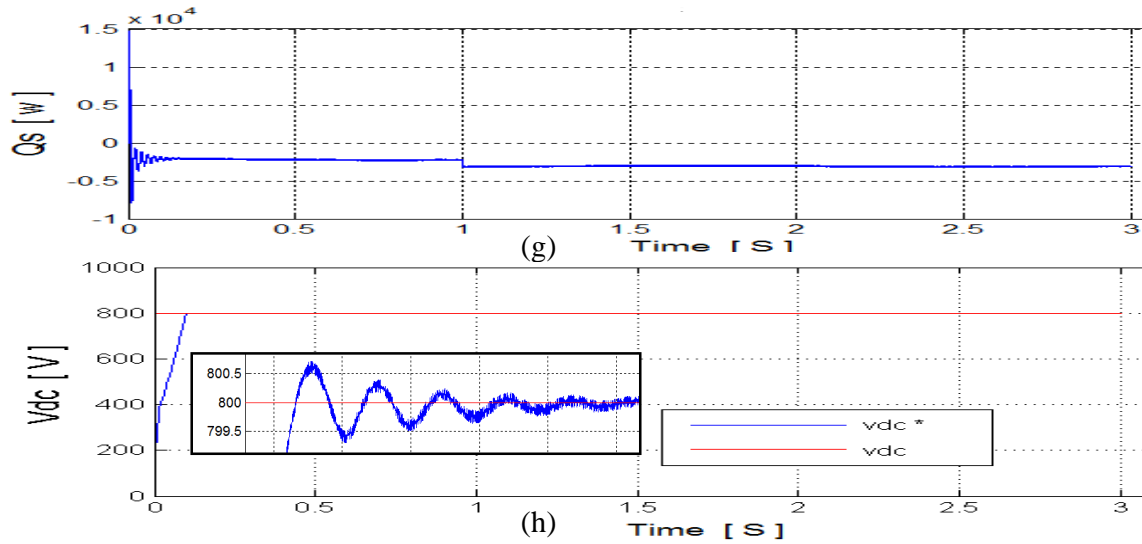

Fig. 7. (a) Wind speed (b) Speed of DFIG with MPPT, (c and d) I_{rd} and I_{rq} currents, (e) Torque, (f) and (g) P_s and Q_s , (h) V_{dc} voltage.

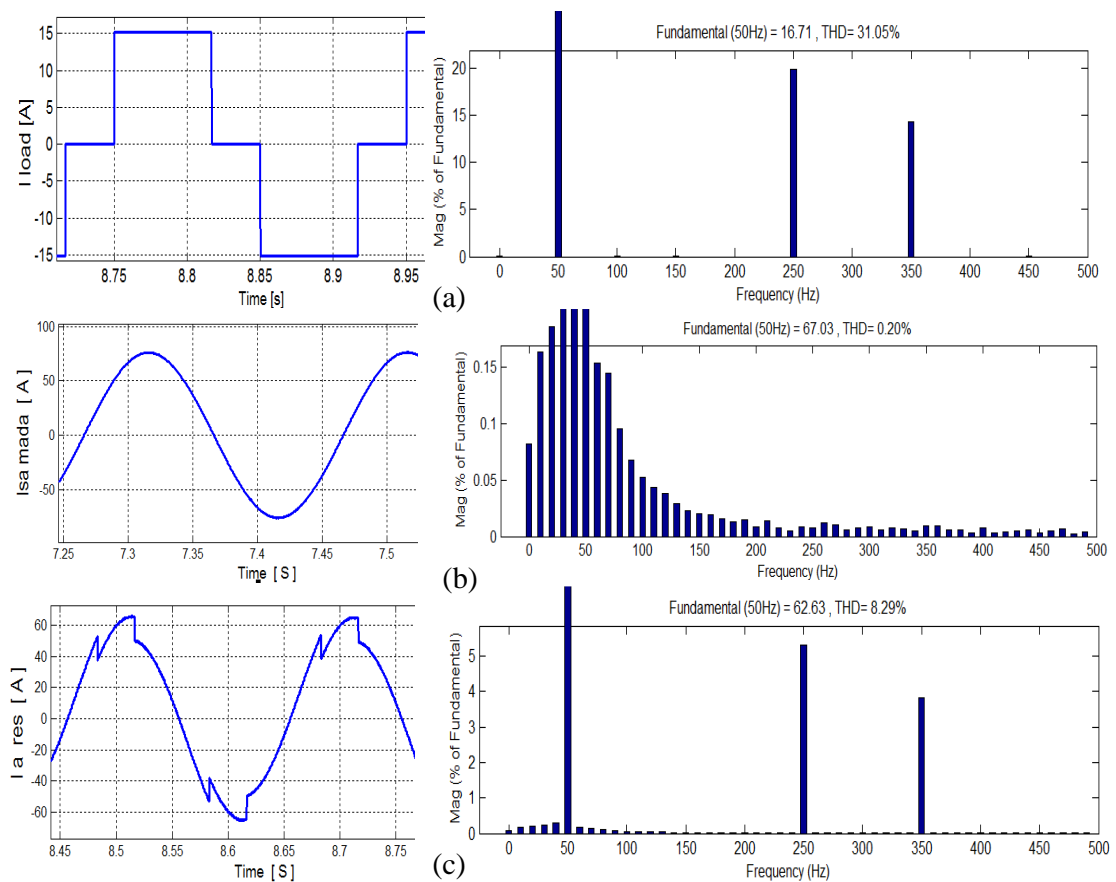

Fig. 8. Current waveforms and their FFT (a) non-linear load, (b) grid, (c) generato

4.2 The priority control method

The block diagram of the priority control method algorithm is depicted in Fig. 9. Where, $I_{rd_reactif}^*$, $I_{rq_actif}^*$ are the references rotor currents and I_{rdh}^* , I_{rqh}^* are the injected harmonics rotor currents.

The MPPT control imposes the reference electromagnetic torque (T^*) which generates the reference quadrature rotor current $I_{rq_reactif}$ which should remain in the range of $\pm I_{rmax}$ to ensure the first priority as shown Equation 9.

$$\sqrt{I_{rd}^2 + I_{rq}^2} = \sqrt{3}I_r = I_{rmax} \quad (9)$$

The direct rotor current reference is generated by the control of the reactive power and should remain between $\pm I_{rdmax}$ to ensure the second priority (Equation.10).

$$I_{rdmax} = \sqrt{I_{rmax}^2 - I_{rq_actif}^2} \quad (10)$$

The third priority which is the harmonic currents control has achieved by the generation of the injected harmonics rotor currents I_{rdh}^* , I_{rqh}^* which must remain between $\pm I_{rdh_max}$, $\pm I_{rqh_max}$ respectively. This priority constraint is implemented using the following rules:

$$\left\{ \begin{array}{l} \text{if } (I_{rd_reactive}^* = \pm I_{rdmax}) \\ \text{then } \left(\begin{array}{l} I_{rdh_max} = 0 \\ I_{rqh_max} = 0 \end{array} \right) \end{array} \right. \quad (11)$$

$$\left\{ \begin{array}{l} \text{if } (-I_{rdmax} < I_{rd_reactive}^* < I_{rdmax}) \\ \text{then } \left(\begin{array}{l} I_{rdh_max} = I_{rdmax} - I_{rd_reactive}^* \\ I_{rqh_max} = I_{rmax} - I_{rq_active}^* \end{array} \right) \end{array} \right. \quad (12)$$

The references for the d and q rotor currents are defined as follows:

$$\left\{ \begin{array}{l} \left[\sqrt{(I_{rd_reactive}^* + I_{rdh}^*)^2 + (I_{rq_active}^* + I_{rqh}^*)^2} \right] \leq I_{rmax} \\ \text{then } \left(\begin{array}{l} I_{rd}^* = I_{rd_reactive}^* - I_{rdh}^* \\ I_{rq}^* = I_{rq_active}^* - I_{rqh}^* \end{array} \right) \\ \text{else } \left(\begin{array}{l} I_{rd}^* = I_{rd_reactive}^* \\ I_{rq}^* = I_{rq_active}^* \end{array} \right) \end{array} \right. \quad (13)$$

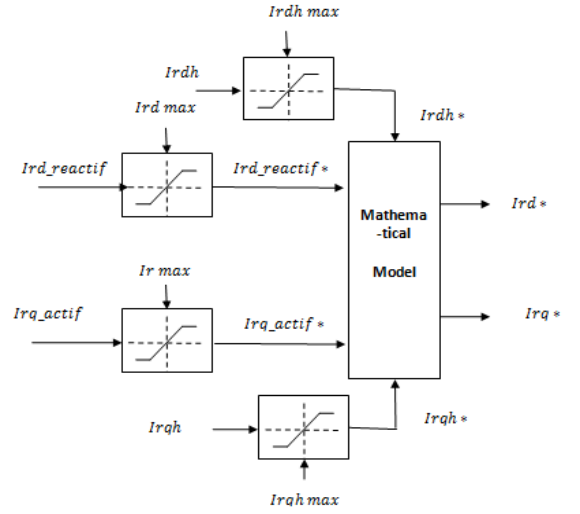

Fig. 9. Priority control method.

4.3 Rotor currents control

The rotor currents controller is based on fuzzy-adaptive PI (proportional-integral) controllers and is implemented as shown in Fig. 10 [12, 17, 18].

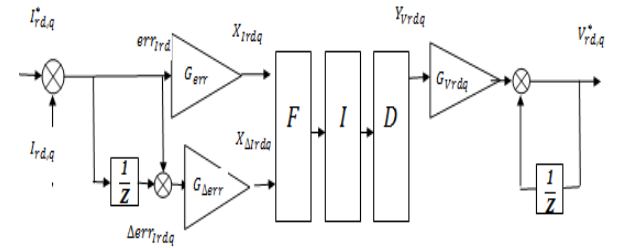

Fig. 10. Bloc diagram of the currents control controller.

Where the F, I and D blocks present respectively the Fuzzification, Inference and rule base and Defuzzification blocks of the fuzzy logic controller.

The fuzzy sets are designated by the labels: NL (negative large), NM (negative medium), NS (negative small), ZE (zero), PS (positive small), PM (positive medium), and PL (positive large).

Fig.11 shows the membership functions for the input variables which are the error (e) and the change of error (Δe) and the output variables are the PI controller gains K_p and K_i . Mamdani-type fuzzy inference system was used and defuzzification was based on the centre of gravity method. Fig. 12 shows the output variables surface of K_p and K_i .

Table 2 and 3 show the control rules of the K_p gain and the K_i gain of the PI fuzzy-adaptive regulator.

Table 1
Fuzzy rules for K_p .

$\frac{e}{\Delta e}$	NB	NM	NS	Zp	PS	PM	PB
NB	PB	PB	PM	PM	PS	Z	Z
NM	PB	PB	PM	PS	PS	Z	Z
NS	PM	PM	PM	PS	Z	NS	NS
Z	PM	PM	PS	Z	NS	NM	NM
PS	PS	PS	Z	NS	NS	NM	NM
PM	PS	Z	NS	NM	NM	NM	NB
PB	Z	Z	NM	NM	NM	NB	NB

Table 3
Fuzzy rules for K_i

$\frac{e}{\Delta e}$	NB	NM	NS	Zp	PS	PM	PB
NB	NB	NB	NM	NM	NS	Z	Z
NM	NB	NB	NM	NS	NS	Z	Z
NS	NB	NM	NS	NS	Z	PS	PS
Z	NM	NM	NS	Z	BS	BM	BM
PS	NM	NS	Z	PS	PS	PM	PB
PM	Z	Z	PS	PS	PM	PB	PB
PB	Z	Z	PS	PM	PM	PB	PB

5. Simulation resultants

In this part, we saved the same conditions of simulation and parameters of turbine, generator and load in the system as the last part in order to compare the simulation results between them.

For the stator powers (active and reactive powers), torque, DC-voltage and speed responses remain invariable as precedents (without active filter), for that we concentrate only in the rotor currents control. The direct and quadrature rotor currents which are shown in Fig.13 illustrate that the PI-fuzzy controller give a good performances like speed responses and low timeout.

Fig. 14 shows the THD of non-linear load not changed equals 31%, the generator one equals 4,29% which is increased then the THD without active filter owing to the injected harmonic currents in the references one, this increase reduces the harmonic currents in the grid form 8% (without filter) to 2,73%.

6. Conclusion

The DFIG doubly accessibility is an important advantage. This induces good control of the power flow between the machine and grid permitting the injection of the power such that the grid power factor is close to unity.

In this paper, we were studying a wind turbine system based on a DFIG with a new method control which permits to improving the energy quality in the grid. At first part; we presented the system with their controls: RSC control, GSC control, the MPPT control and with a simple non-linear load. The simulations results of FFT currents waveform had shown the high harmonic pollution currents in the grid. For that we were including a new method control to reduce this harmonic currents without change the principal controls (stator powers control and MPPT control) using active shunt filter. This method called priority method control which permits to manage the priority control between the stator powers and the injected harmonic currents, so we used an active shunt filter with a SFR method and in order to obtain a high performance we used also an adaptive-fuzzy PI controller to control the rotor currents. The second simulation results show the reducing of THD in the harmonic currents in the grid from 8% to 2.73%, without affected in the others variables control.

6. References

1. Muller, S. Deicke M, Doncker R W De.: *Doubly fed induction generator systems for wind turbines*. IEEE Ind. Appl. Mag., vol. 17, no. 1, pp. 26–33, May–Jun. 2002.
2. Pena, R. Clare, J. C. Asher, G. M.: *Double fed induction generator using back-to-back PWM converter and its application to variable-speed wind-energy generation*. Proc. IEE B Electr. Power Appl., vol. 143, no. 3, pp. 231–241, May 1996.
3. Muller, S. Deicke, M. Rik, W.: *Doubly Fed Induction Generator for Wind Turbine*. IEEE Industry Application Magazine • May-June 2002 .
4. Lie, Xu.: *Direct Active and Reactive Power Control of DFIG for Wind Energy Generation*. IEEE Transactions on Energy conversion, September 2006.
5. Hopfensperger, B. Atkinson, D. Lakin, R. A.: *Stator flux oriented control of a cascaded doubly-fed induction machine*. IEE Proc. Electr. Power Appl., vol. 146, no. 6, pp. 597–605, Nov. 1999.
6. Akagi, H. Watanabe, E. H. Aredes, M.: *Instantaneous Power Theory and Applications to Power Conditioning*. Hoboken. NJ: Wiley-IEEE. Press, Apr. 2007.
7. Kunju muhammed, L. P. Mishra, M. K.: *Comparison of single phase shunt active power filter algorithms*. In: Proc. Annu. Conf. IEEE Power India, 2006.
8. Uyyuru, K. R. Mishra, M. K, Ghosh, A.: *An optimization-based algorithm for shunt active filter under distorted supply voltages*. IEEE Trans. Power Electron.
9. Zadeh, L. A.: *Fuzzy logic*. Computer, vol. 21, pp. 83–84, April, 1988.
10. Kesler, M. Ozdemir, E. *Synchronous-Reference-Frame-Based Control Method for UPQC Under Unbalanced and Distorted Load Conditions*. IEEE Transactions on Industrial Electronics, vol. 58, no. 9, September 2011.

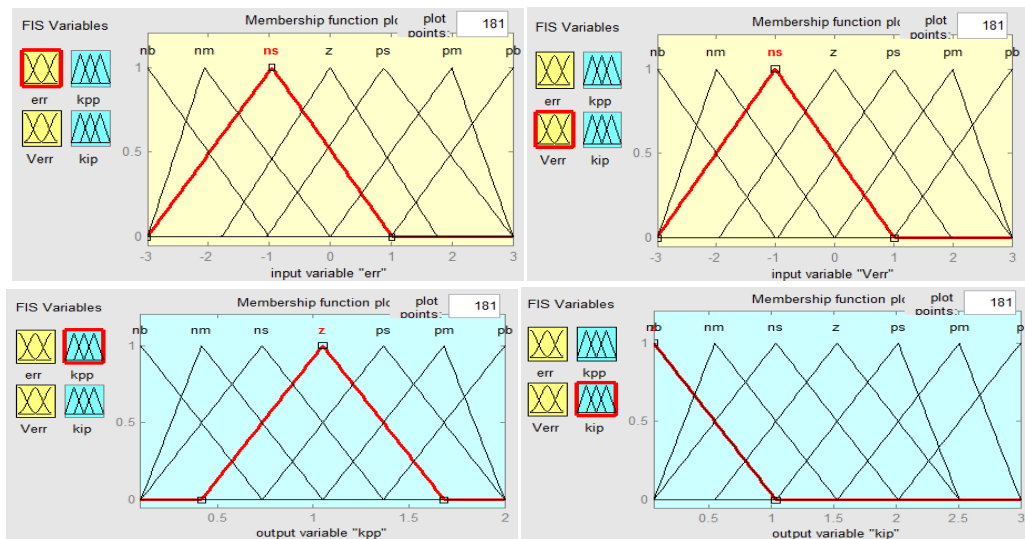

Fig. 5. Membership functions for input variables e , Δe and output K_p and K_i .

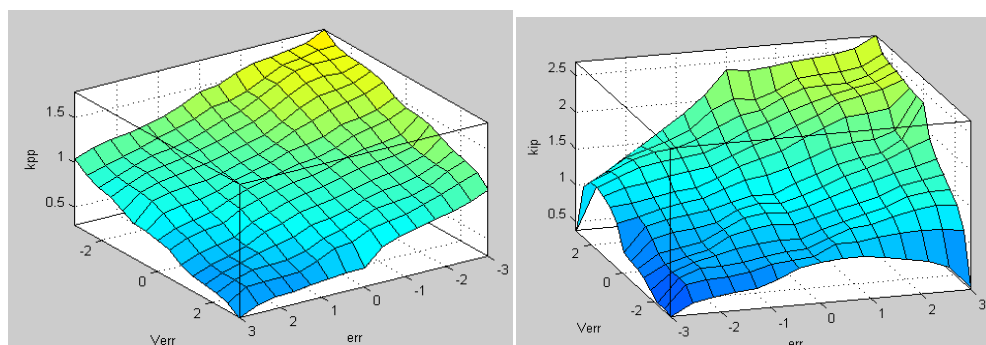
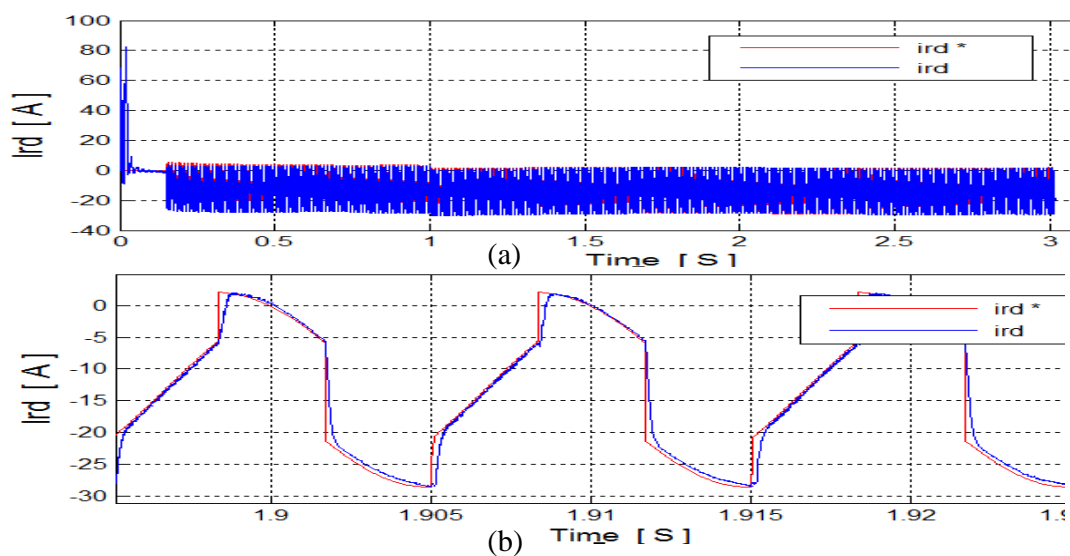

Fig. 62. Output variables surface of K_p and K_i .



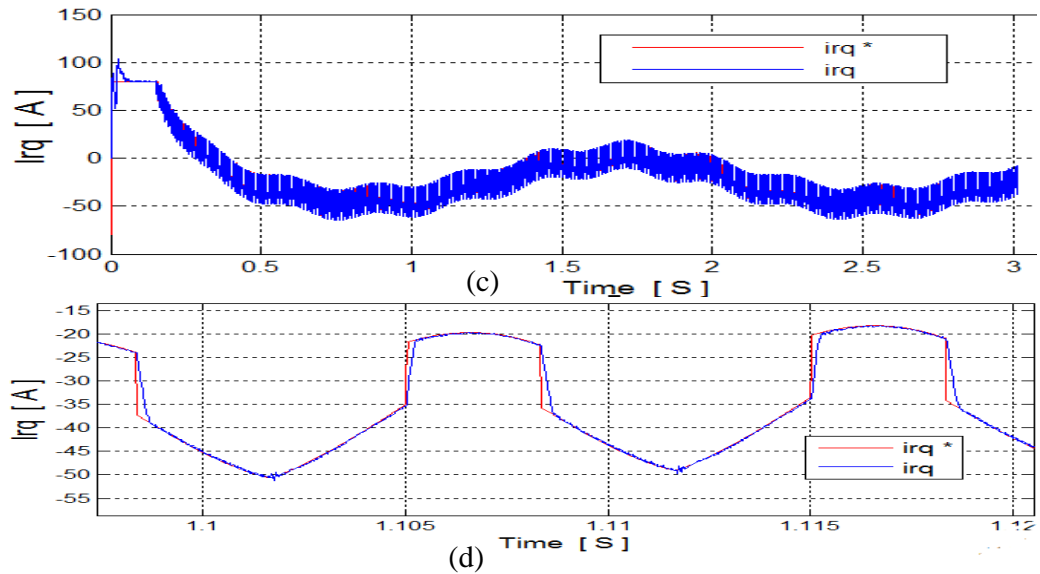

Fig. 7. Rotor currents wavefoms: (a) I_{rd} , (b) zoom of I_{rd} , (c) I_{rq} , (d) zoom of I_{rq} .

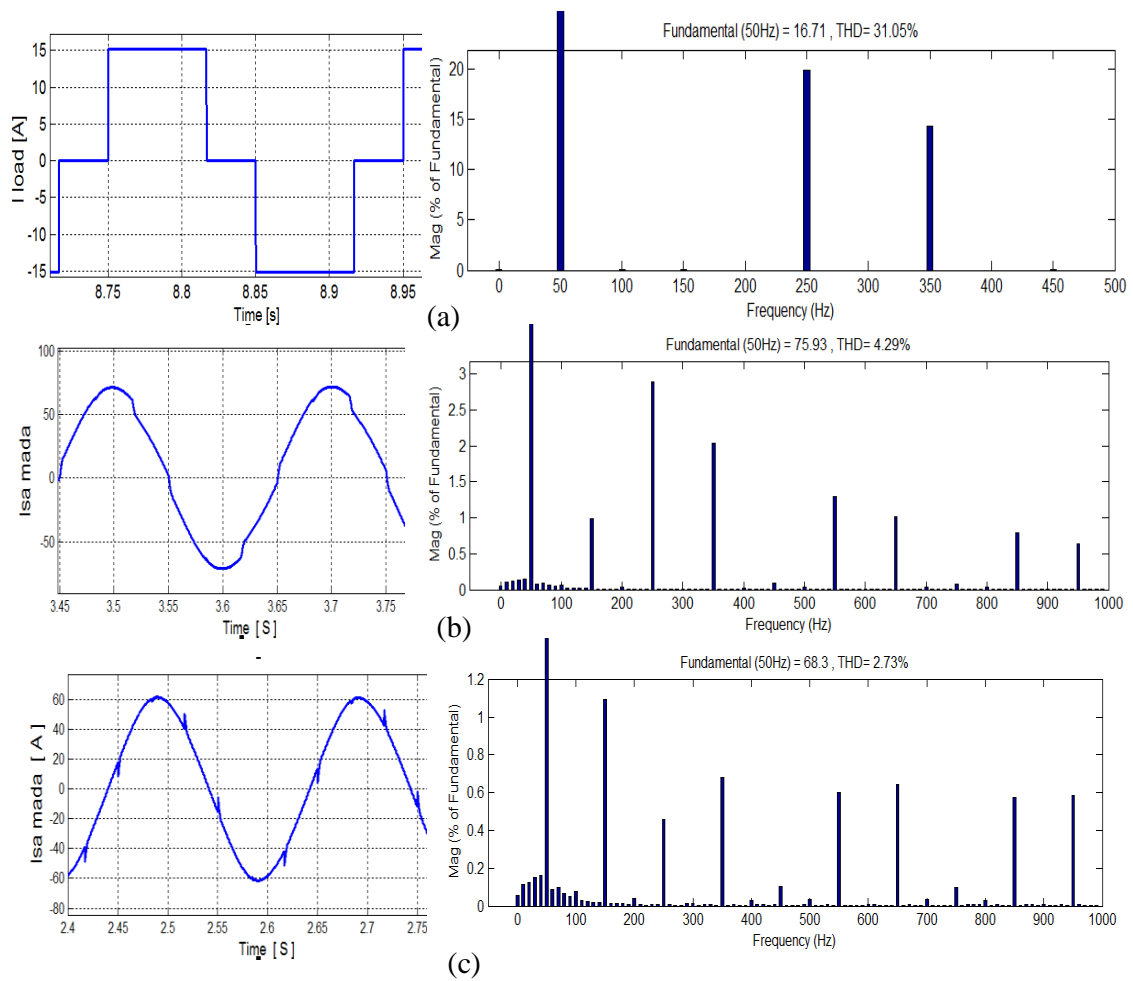

Fig. 8. Currents waveforms and FFT with active filter (a) non-linear load, (b) grid, (c) generator.

11. Durgadevi, A. Arulselvi, S. Natarajan, S. P.: *Study and Implementation of Maximum Power Point Tracking (MPPT) Algorithm for Photovoltaic Systems*. 978-1-61284-379. Mai. 2011 IEEE.
12. Lei, W.: *Design of a Hybrid Fuzzy Logic Proportional Plus Conventional Integral-Derivative Controller*. IEEE Transactions on fuzzy system, Nov. 1998.
13. Durgadevi, A. Arulselvi, S.: *Natarajan S P. Study and Implementation of Maximum Power Point Tracking (MPPT) Algorithm for Photovoltaic Systems*. 978-1-61284-379-November. 2011 IEEE.
14. Zou, Y. Elbuluk, M. E. Sozer, Y.: *Stability Analysis of Maximum Power Point Tracking (MPPT) Method in Wind Power System*. IEEE Transactions on Industry Applications. vol. 49, No. 3, Mai-June 2013.
15. Shukla, R. D. Tripathi, R. K.: *Maximum Power Extraction Schemes and Power Control in Wind Energy Conversion System*. International Journal of Scientific and Engineering Research. Volume 3. Issue 6. June-2012.
16. Djeriri, Y. Meroufel, A. Massoum, A. Boudjema, Z.: *A Comrarative Study Between Field Oriented Control Strategy and Direct Power Control Strategy for DFIG*. Journal of Electric Engineering
17. Shanthi, B. Natarajan, S. B. Anbukodi S. B.: *Fuzzy Logic Control For Single Phase Multilevel Inverter*. Journal of Electric Engineering.
18. Tunyasriru, S.: *Adaptive Fuzzy PI Controller for Speed of Separately Excited DC Motor*. 1999 IEEE. VI- 196- VI-201.
19. Brekken; TKA. Mohan, N.: *Control of a doubly fed induction wind generator under unbalanced grid voltage conditions*. IEEE Transactions.
20. Miret, J. Castilla, M. Matas, J. Guerrero, J. M. Vasquez, J. C.: *Selective harmonic-compensation control for single-phase active power filter with high harmonic rejection*. IEEE Trans. Ind. Electron., Vol-56, No-8. Aug. 2009.pp. 3117-3127.
21. Marques, G. D.: *A comparison of active power filter control methods in unbalanced and non-sinusoidal conditions*. In Proc. 24th IEEE IECON. 1998. Vol-1. pp. 444-449.
22. Tunyasrirut, S.: *Adaptive Fuzzy PI Controller for Speed of Separately Excited DC Motor*. 1999 IEEE. VI- 196- VI-201.
23. Zhang, X. Cheng, J. Wang, W.: *The Intelligent Control Method Study of Variable Speed Wind Turbine Generator*. August 2008 IEEE.
24. Aredes, M.: *A combined series and shunt active power filter*. In Proc. IEEE/KTH Power Tech Conf. Stockholm. Sweden. Jun. 1995, pp. 18-22.
25. Takagi, T. Sugeno, M.: *Fuzzy identification of systems and its applications to modeling and control*. IEEE Trans on systems. Man and Cybernetics. Vol-15. No-1. January 1985.pp.116-132.