

**ACPAT Seminar 2018
Equine Day**

Advances in Electrotherapy

Professor Tim Watson
University of Hertfordshire
www.electrotherapy.org

- ### Topic Areas
- Electrotherapy vs Electrophysical Agents/Modalities
 - Electrophysical Framework
 - Electrophysical Forum
 - Popularity, Evidence and New Device Hype
 - **Radiofrequency Interventions** – newly developing field in Equine practice
 - **Low Intensity Pulsed Ultrasound (LIPUS)** – is it a viable Equine option for interventions beyond fracture management?

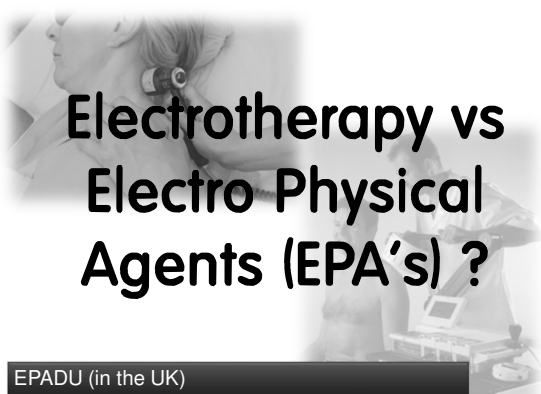

Electrotherapy vs Electro Physical Agents (EPA's) ?

EPADU (in the UK)
ISEAPT as a sub group of WCPT i.e. worldwide

Electrophysical Framework

Electrical Stimulation Agents / Modalities	Thermal Agents / Modalities	Non Thermal Agents / Modalities
Transcutaneous Electrical Nerve Stimulation (TENS)	Infra Red Irradiation (IRR)	[Pulsed] Ultrasound
Neuromuscular Electrical Stimulation (NMES)	Shortwave Diathermy (SWD)	Low Intensity Pulsed Ultrasound (LIPUS)
Interferential Therapy (IFT)	Microwave Diathermy (MWD)	[Pulsed] Shortwave Therapy (PSWT)
Functional Electrical Stimulation (FES)	Other RF Therapies [Indiba, Tecar]	[Pulsed] Laser Therapy (LLLT / LILT)
Faradic Stimulation: Diadynamic Therapy	Hydrocollator Packs	
Iontophoresis	Wax Therapy	
High Voltage Pulsed Galvanic Stimulation (HVPGS)	Balneotherapy (inc spa/whirlpool)	Low Intensity RF Applications [e.g. Indiba; Tecar]
Low Intensity Direct Current (LIDC) and Pulsed LIDC	Fluidotherapy	Pulsed Electromagnetic Fields (PEMF's)
Twin Peak Monophasic Stimulation	Therapeutic Ultrasound	[Pulsed] Microwave Therapy
H Wave Therapy®; Action Potential System (APS)	Laser Therapy	(Radial) Shockwave Therapy
Russian Stimulation : Aussie Stim: Medium Frequency Stimulation (BMAC)		MAGNETIC THERAPIES
Rebox Therapy; Scenar Therapy, NRN (InterX) based therapy	Cryotherapy / Cold Therapy / Ice / Immersion Therapy	[Static Magnetic Therapy] [Pulsed Magnetic Therapy]
Microcurrent Therapy (MCT)	Contrast Baths	Microcurrent Therapy (MCT)

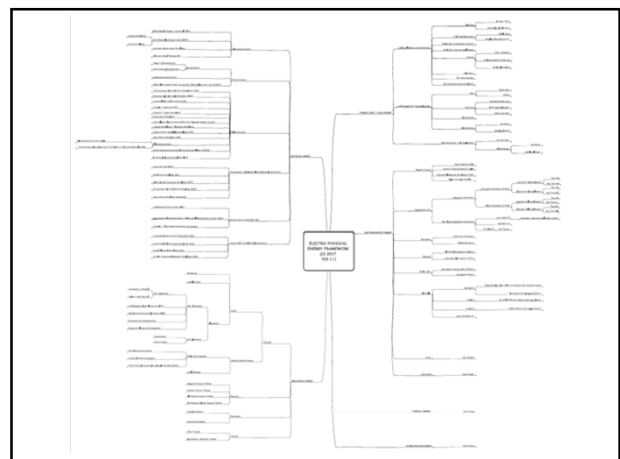

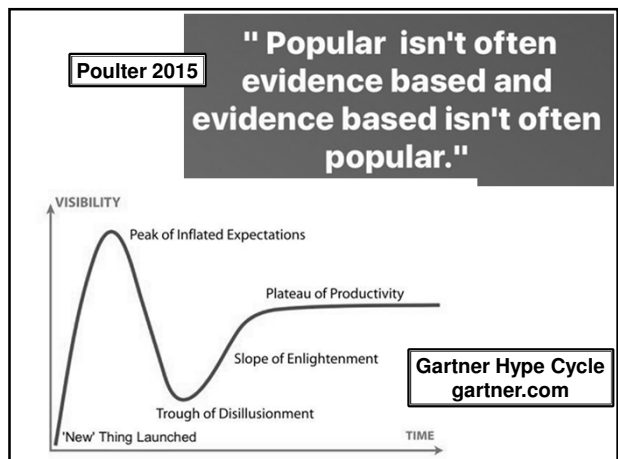
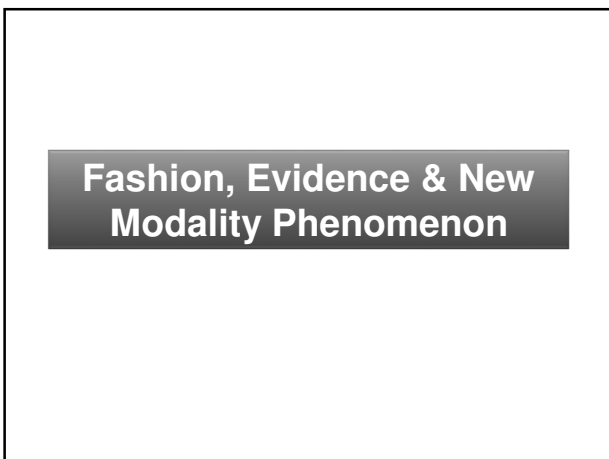
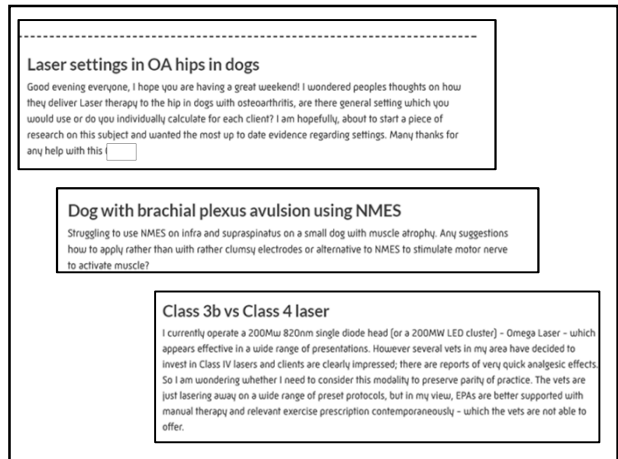
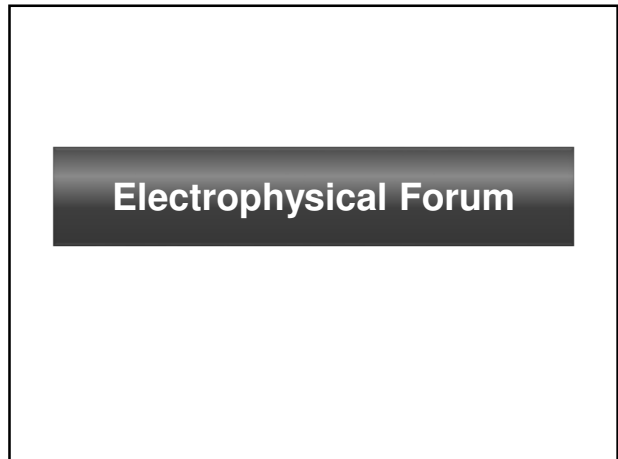
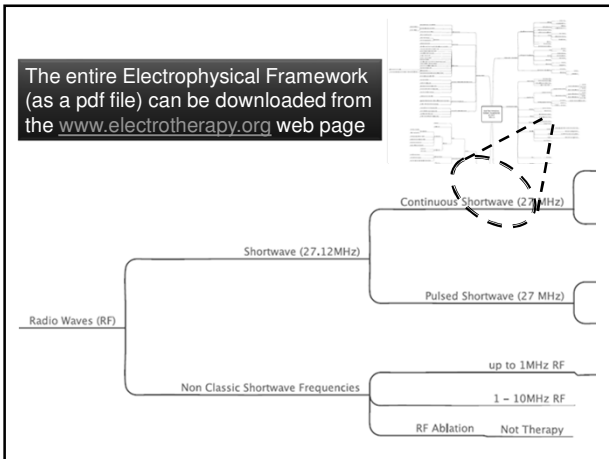

Radiofrequency Therapy in Equine Rehabilitation



Electrical Stimulation Agents / Modalities	Thermal Agents / Modalities	Non Thermal Agents / Modalities
Transcutaneous Electrical Nerve Stimulation (TENS)	Infra Red Irradiation (IRR)	[Pulsed] Ultrasound
Neuromuscular Electrical Stimulation (NMES)	Shortwave Diathermy (SWD)	Low Intensity Pulsed Ultrasound (LIPUS)
Interferential Therapy (IFT)	Microwave Diathermy (MWD)	[Pulsed] Shortwave Therapy (PSWT)
Functional Electrical Stimulation (FES)	Other RF Therapies [Indiba, Tecar]	[Pulsed] Laser Therapy (LLLT / LLIT)
Faradic Stimulation: Diadynamic Therapy	Hydrocollator Packs	
Iontophoresis	Wax Therapy	
High Voltage Pulsed Galvanic Stimulation (HVPGS)	Balneotherapy (inc spa/whirlpool)	Low Intensity RF Applications [e.g. Indiba; Tecar]
Low Intensity Direct Current (LIDC) and Pulsed LIDC	Fluidotherapy	Pulsed Electromagnetic Fields (PEMF's)
Twin Peak Monophasic Stimulation	Therapeutic Ultrasound	[Pulsed] Microwave Therapy
H Wave Therapy [®] ; Action Potential System (APS)	Laser Therapy	(Radial) Shockwave Therapy
Russian Stimulation - Aussie Stim: Medium Frequency Stimulation (BMAC)		MAGNETIC THERAPIES
Rebox Therapy; Scenar Therapy, NRN (InterX) based therapy	Cryotherapy / Cold Therapy / Ice / Immersion Therapy	[Static Magnetic Therapy] [Pulsed Magnetic Therapy]
Microcurrent Therapy (MCT)	Contrast Baths	Microcurrent Therapy (MCT)

Radiofrequency in Therapy and Rehabilitation

- Long history in both human and animal therapy
- Some fashion based variable use
- Significant evidence base
- Shift in emphasis for 'modern' use
- Indiba is a machine which is made for use in both Human and Animal clinical areas
- Delivers a specific 'mode' of RF
- There are others available, but this is the only SPECIFIC animal / veterinary device that I have identified

RF as part of EM Spectrum

Radiofrequency range						
Infrared (non-RF)	EHF RF	SHF RF	UHF RF	Normal range RF	VLF RF	ELF EMF (non-RF)
Frequency above 300 GHz	30 - 300 GHz	3 - 30 GHz	0.3 - 3 GHz	30 KHz - 300 MHz	3 - 30 KHz	Frequencies below 3 KHz

- Classically, RF used in therapy includes
 - Shortwave (typically at 27.12MHz) ↑
 - Microwave (typically around 2450MHz) ↑
 - New (indiba type) application at around 0.5MHz ↑

Recent Reviews

Kumaran and Watson (2015). Radiofrequency-based treatment in therapy-related clinical practice – a narrative review. Part I: acute conditions Physical Therapy Reviews 20(4): 241-254.

Narrative Review
Radiofrequency-based treatment in therapy-related clinical practice – a narrative review. Part I: acute conditions
Binoy Kumaran and Tim Watson

Radiofrequency-based treatment in therapy-related clinical practice – a narrative review. Part II: chronic conditions

Binoy Kumaran & Tim Watson

Kumaran and Watson (2016). Radiofrequency-based treatment in therapy-related clinical practice – a narrative review. Part II: chronic conditions Physical Therapy Reviews 20(5):325-343

Review(s) Summary

- Considered Shortwave and Non-Shortwave literature
- Narrative Reviews – all relevant literature
- In ACUTE group, dominated by Shortwave literature (n=30 papers)
- Main effectively treated clinical issues were:
 - Pain and Inflammation (post operative, post injury, post fracture, other misc acute pains) (n=22)
 - Tissue Healing/Repair (post op, bone healing, wound healing) (n=7)
 - Other MISC conditions (pneumothorax) (n=1)

Chronic Papers Review

- Larger group of publications (n=90)
- Includes Shortwave (n=82) and Non-Shortwave (n=8) frequencies
- Shortwave supportive evidence in
 - Osteoarthritis
 - Chronic pain
 - Chronic Wounds
- Non Shortwave studies
 - chronic joint problems (knee, shoulder)
 - tendinopathy + other soft tissue problems

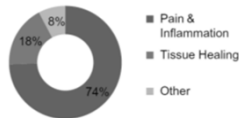

Summary Cell Studies + In Vitro Work

Effects evidenced : Cell Level

- Significant volume of work
- Restrict here to non shortwave (e.g. Indiba frequency of 448kHz) (mainly Ubeda-Maeso, Hernández-Bule + team, in Madrid)
- Numerous established cell level responses
- At NON THERMAL levels
- Mechanisms identified
- Consistent with gross Electromagnetic Field evidence base (which is extensive)
- Dose dependency also appears to be real (also consistent with other interventions)

Design and methodology for in vitro electrical stimulation

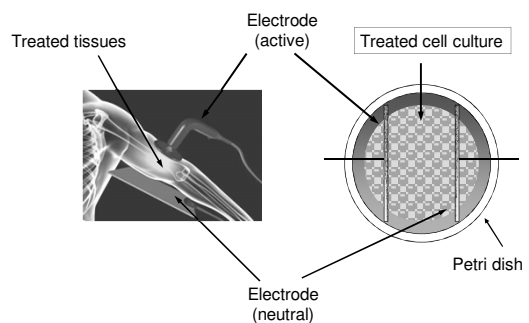

Cell Level Studies Include:

- Cell Death and Viability – is it safe?
YES
- Cell Proliferation and Differentiation
EFFECTIVE
[has potential for post stem cell therapy treatment]
- Potential Transduction Pathways
ESTABLISHED

Ongoing Stem Cell work

- Cartilage (Chondrogenesis)
 - INDIBA enhances molecular processes involved in chondrogenesis
 - “The present data set provides support to the hypothesis that the electric component of the electrothermal treatment applied in CRET therapies could stimulate cartilage repair by promoting chondrogenic differentiation”
 - The effect is post-transcriptional, at the protein synthesis level
 - Key findings just published (Hernandez-Bule et al 2018 J Stem Cell Research + Therapy)
- Bone (Osteogenesis):
 - Work underway – not yet in the public domain
 - BUT looks promising (at in vitro stage)

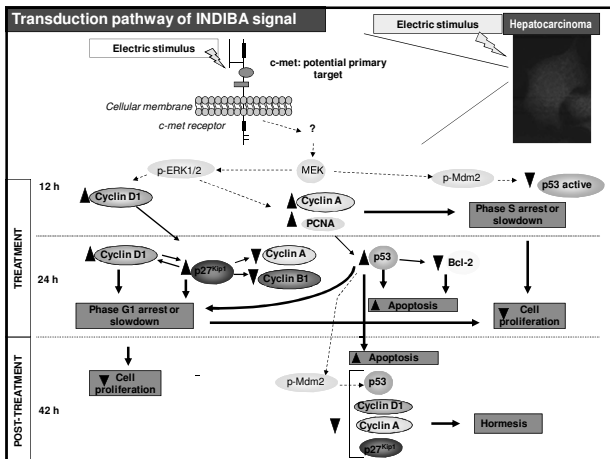

- Effects Evidenced: Gross Physiological**
- Series of Studies in asymptomatic (healthy) individuals
 - Kumaran + Watson (several published, several in process)
 - Investigated
 - Temperature changes
 - Blood Flow changes (superficial + deep)
 - Nerve Conduction
 - Tissue Elastography
 - Central (BP, Heart Rate)

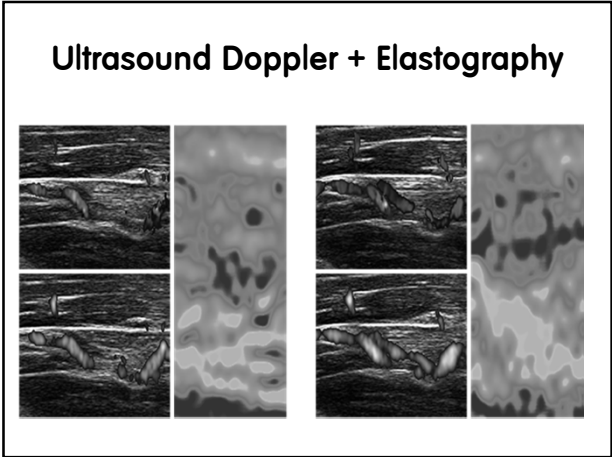
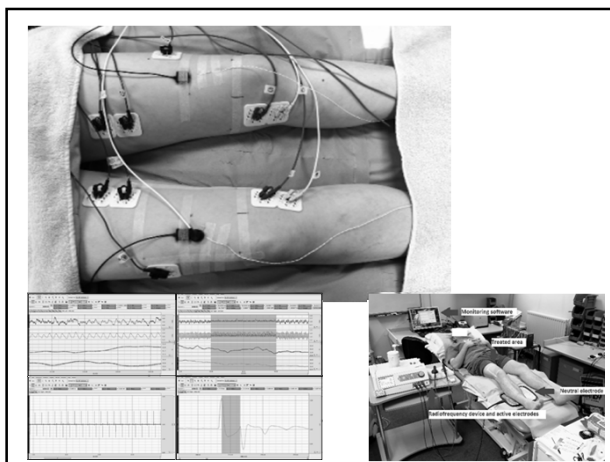

- Summary Findings**
- Variable dose response to thermal effects, best judged subjectively (individual response) rather than set dose
 - Sig changes in SKIN TEMPERATURE
 - Sig changes in SKIN BLOOD FLOW
 - Sig changes in DEEP BLOOD FLOW
 - All these effects MORE PRONOUNCED and LONGER LASTING than with nearest therapy equivalent (shortwave)
 - No sig effect on NCV, BP or H Rate

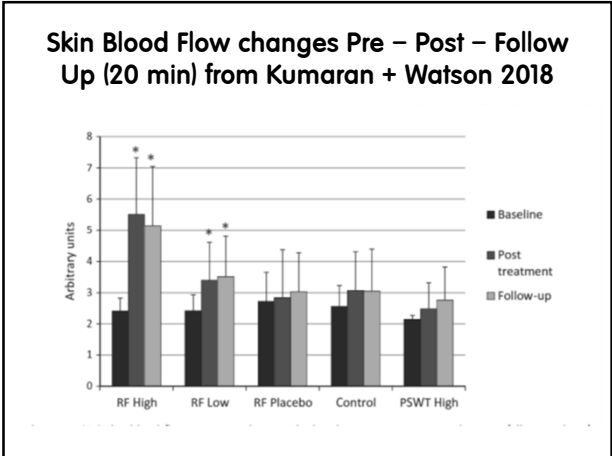

Deep Blood Flow (Volume) changes

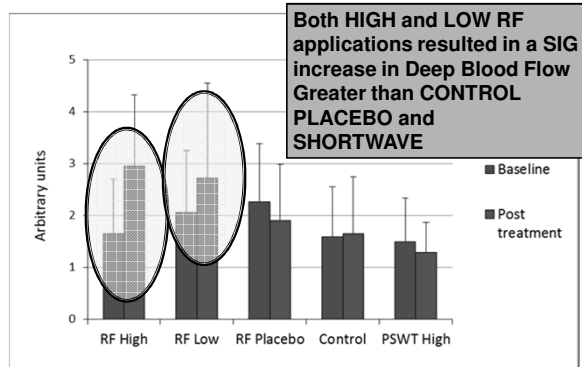

Effects Evidenced : Clinical

- Recently completed
- Results not yet published (in press)
- Patients (human) with OA knee
- 3 groups (verum Indiba, placebo Indiba, standard care (control))
- Statistically powered to show effect if present
- 8 x session (15min, 5 min CAP + 10 min RES) over 4 weeks
- Follow-up at 1 and 3 months post intervention
- Some design issues constrained by Ethics

Results (in general)

- **Outcomes**
 - PAIN – positive effect
 - WOMAC - positive effect
 - ROM + Function tests - positive effect
 - Replicate physiological tests from healthy subject studies (PATIENTS appear to have ENHANCED ENERGY SENSITIVITY – same effect at LOWER DOSE (or BIGGER EFFECT at SAME DOSE))

A 4 week high dose of Indiba intervention (producing a moderate thermal response) delivered alongside exercise and self management advice in patients with OA Knee brought about a statistically significant and clinically meaningful reduction in PAIN as well as improvement in FUNCTION. These improvements were maintained at follow up (1 and 3 months).

The effects were significantly greater than those achieved with a placebo Indiba treatment or in a control group who received current standard care (exercise and advice)

Effects Evidenced : Veterinary



INDIBA ANIMAL HEALTH
Guidelines



INDIBA
ANIMAL HEALTH

VET 905

Example Treatments + Protocols

- Numerous Veterinary applications, including significant range in EQUINE based therapies
- Protocols based on best evidenced equine practice - therapist experience
- Growing body of research publications

Indiba based therapy in Equine Practice

Pathologies	Wellness therapy
<ul style="list-style-type: none"> Tendopathies Desmopathies Athropathies Back pain Sacroiliac pain Wound healing 	<ul style="list-style-type: none"> Poll and cervical transit region, back and sacroiliac joint. Performance improving and calm down after the competition.

Hoof pathologies:
Navicular syndrome
Tendonitis DDFT
Sinovitis Coffin joint
Desmitis
Laminitis

DDBC: Lipo-PRE
Stem cell therapy

Developing Areas

Animal Health Protocols



Protocol	Indication
Improved Performance and Recovery	General session for improving performance in the Competition Horse and Recovery post-exercise
Gluteus stiffness, Semimembranosus, Semitendinosus, Pectoral Muscle stiffness, Back pain	Stiffness, remove contractures and relaxation in stifle areas and mild pain
Calmer and Relaxation	Calming the horse before competition
Sacroiliac Injuries	Decrease pain and stiffness in area. Increase mobility
Osteoarthritis Tarsal/Carpal	Chronic/Acute arthritis. Decrease inflammation and pain
Suspensory Desmitis - DDFT/SDFT Damage	Drainage oedema, neovascularisation
Stifle Injuries	Stiffness and swelling in the area
Fetlock Strain	Drainage oedema. Decrease inflammation
Nuchal ligament	Decrease pain, remove contracture, increase mobility
Windgalls	Excess fluid in fetlock joint

These are **general** protocols. They must be adapted to each individual equine patient according to their needs and clinical situation

Semimembranosus - Semitendinosus stiffness

16 minutes



Objective : Vasoilatation, remove contractures
Installation return electrode : On the abdomen
Precaution : Feeling (IAS) perception therapist

Electrode	Duration	Treatment	IAS
CAP 	4 min (total)	Over left and right Semimembranosus and Semitendinosus (2 min each side)	40% ③ ④
RES 	10 min (total)	Over left and right Semimembranosus and Semitendinosus (5 min each side)	50% ⑥
CAP 	2 min (total)	Over left and right Semimembranosus and Semitendinosus (1 min each side)	40% ③

Interosseous Desmitis Sacroiliac Ligament

20 minutes



Objective: decrease of pain, remove contractures, increasing mobility
Installation return electrode : On the abdomen
Precaution : Feeling (IAS) by the therapist

Electrode	Duration	Treatment	IAS
CAP 	3 min	Gently massage the sacroiliac area	40% ③
RES 	15 min	Gently massage the sacroiliac area taking into account system readings	45-50% ⑤ ⑥
CAP 	2 min	Gently massage the sacroiliac area	40% ③

Stifle Injuries

20 minutes

Objective : Drainage, decrease inflammation, reduce pain and stiffness
Installation return electrode : On the abdomen
Precaution : Feeling (IAS) perception therapist. Exclude vascular lesion

Electrode	Duration	Treatment	IAS
CAP 	3 min	Gently massage the stifle area	40% ③ ④
RES 	12 min	Gently massage the stifle area taking into account system readings	20% ⑤
CAP 	5 min	Gently massage the stifle area	40% ③ ④

Summary

- RF used for many years as a therapy tool
- Shortwave (27.12MHz) historically most popular
- Operation at 0.448MHz (448kHz) with Indiba in CAPACITIVE and RESISTIVE modes
 - Cell studies
 - Gross Physiology studies
 - Clinical studies
 - Veterinary studies

General Outcomes

- SUPPORTIVE of a real effect, over and above that of placebo or control
- Cell studies : (inc proliferation and differentiation at non thermal levels)
- Gross Physiological : significant effects over and above placebo, control and nearest equivalent therapies
- Clinical : positive outcomes in a chronic condition
- Veterinary: Positive experiences and a range of supportive studies

LOW INTENSITY PULSED ULTRASOUND :: LIPUS ::



Electrical Stimulation Agents / Modalities	Thermal Agents / Modalities	Non Thermal Agents / Modalities
Transcutaneous Electrical Nerve Stimulation (TENS)	Infra Red Irradiation (IRR)	[Pulsed] Ultrasound
Neuromuscular Electrical Stimulation (NMES)	Shortwave Diathermy (SWD)	Low Intensity Pulsed Ultrasound (LIPUS)
Interferential Therapy (IFT)	Microwave Diathermy (MWD)	[Pulsed] Shortwave Therapy (PSWT)
Functional Electrical Stimulation (FES)	Other RF Therapies [Indiba, Tecar]	[Pulsed] Laser Therapy (LLLT / LILT)
Faradic Stimulation: Diadynamic Therapy	Hydrocollator Packs	
Iontophoresis	Wax Therapy	
High Voltage Pulsed Galvanic Stimulation (HVPGS)	Balneotherapy (inc spa/whirlpool)	Low Intensity RF Applications [e.g. Indiba; Tecar]
Low Intensity Direct Current (LIDC) and Pulsed LIDC	Fluidotherapy	Pulsed Electromagnetic Fields (PEMF's)
Twin Peak Monophasic Stimulation	Therapeutic Ultrasound	[Pulsed] Microwave Therapy
H Wave Therapy*; Action Potential System (APS)	Laser Therapy	(Radial) Shockwave Therapy
Russian Stimulation : Aussie Stim: Medium Frequency Stimulation (BMAC)		MAGNETIC THERAPIES
Rebox Therapy; Scenar Therapy, NRN (InterX) based therapy	Cryotherapy / Cold Therapy / Ice / Immersion Therapy	[Static Magnetic Therapy] [Pulsed Magnetic Therapy]
Microcurrent Therapy (MCT)	Contrast Baths	Microcurrent Therapy (MCT)

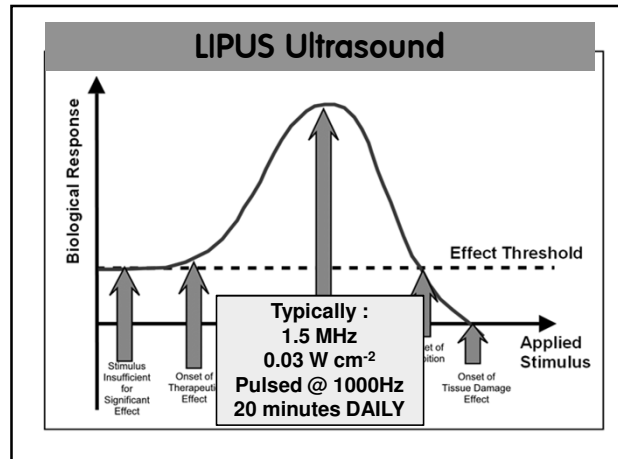

Bone Healing - Established

- Significant volume of evidence to support clinical use in
 - Fresh Fractures (reduces time to healing by up to 35-40%)
 - Delayed Union (instigates a repair response with an average success rate of 91%) (Mayr et al 2000)
 - Non Union (instigates a repair response with an average success rate of 86%) (Mayr et al 2000)
- LIPUS has been shown to enhance fracture healing by shortening the time to heal and reestablishment of mechanical properties through enhancing different phases of the healing process, including the inflammatory phase, callus formation, and callus remodelling phase (Zhang et al 2017)
- [summarised with refs at electrotherapy.org]

Other LIPUS Applications

- Given strength and volume of Bone Healing research, other areas under investigation
- Includes
 - Cartilage repair / regeneration
 - Nerve Repair
 - Stem Cell Activation / Facilitation

Rothenberg et al (2017)

The Role of Low-Intensity Pulsed Ultrasound on Cartilage Healing in Knee Osteoarthritis: A Review
PM&R 9(12):1268-1277.

- The purpose of this review was to critically examine the medical literature to determine the effects of LIPUS on the chondrogenic properties of knee osteoarthritis
- A literature search of 3 major databases (PubMed, Scopus, and EMBASE) was performed. Two independent reviewers screened titles and abstracts, yielding a total of 18 relevant articles (14 animal, 4 human)

Collagen Expression

- 10 studies evaluated the effect of LIPUS on type II collagen expression.
- All of these were randomized studies.
- Nine studies showed significantly increased expression of type II collagen
- [advantageous]

Histology

- 8 studies examined the histologic effects of LIPUS on articular cartilage
- All of these studies found significant improvements in chondral histology with LIPUS treatment.
- In addition, the gross appearance of cartilage as evaluated under microscopy was also significantly improved
- [advantageous]

Mechanism / Pathway

- 8 studies evaluated the effect of LIPUS on the expression of MMP-13, a protein involved in cartilage degradation that is overexpressed in osteoarthritis
- All RCT's involving animal models.
- All studies showed a significant decrease in MMP-13 expression after LIPUS treatment
- [advantageous]

Summary / Conclusion

" Based on the review, the preliminary evidence demonstrates the potential positive benefits of LIPUS on chondrogenic properties in an animal model"

" With knee osteoarthritis as one of the most debilitating conditions, LIPUS serves as a potentially promising therapeutic option in the future for prevention of degeneration of articular cartilage"

Additionally

- Zahoor et al. (2018) Effect of Low-Intensity Pulsed Ultrasound on Joint Injury and Post-Traumatic Osteoarthritis: an Animal Study. *Ultrasound Med Biol* 44(1): 234-242.
- . . . In conclusion, LIPUS treatment partially improved the gait of the affected limbs and reduced cartilage degeneration in Post Traumatic OA. . . .
- Zhao et al (2016) Low-Intensity Pulsed Ultrasound Enhances Nerve Growth Factor-Induced Neurite Outgrowth through Mechano-transduction-Mediated ERK1/2-CREB-Trx-1 Signaling. *Ultrasound Med Biol* 42(12): 2914-2925.
- The combination of LIPUS and NGF could potentially be used for the treatment of nerve injury and neurodegenerative diseases. . . .

Yamaguchi et al (2016) Effect of Low-Intensity Pulsed Ultrasound after Mesenchymal Stromal Cell Injection to Treat Osteochondral Defects: An In Vivo Study. Ultrasound Med Biol 42(12): 2903-2913.

“ Mesenchymal Stromal Cell injection combined with LIPUS irradiation is more effective than either treatment alone in promoting concurrent cartilage repair and subchondral reconstitution. . . . ”

Conclusions

- Electrotherapy vs Electrophysical Agents/Modalities :
Electrophysical is a preferred term
- Electrophysical Framework
Full exploration of Modalities with capacity to expand
- Electrophysical Forum
An opportunity to SHARE and LEARN from others with significant Animal Therapy content
- Popularity, Evidence and New Device Hype
Enough said!

Radiofrequency Application

- RF applications have potential as a 'new' therapy (beyond the hype!)
- Developing field in Animal Therapy with strong uptake in specialist Equine centres (USA, UK, Europe, Middle East)
- Significant lab and clinical results with stronger and longer lasting effects than existing therapy

Low Intensity Pulsed Ultrasound (LIPUS)

- Established in bone healing [Fresh Fracture healing, Delayed Union + Non Union management]
- Interesting advances with regards
 - Cartilage Repair and 'regeneration'
 - Stimulation of Stem Cells post injection/implant
 - Stimulation of Nerve Repair / Recovery (prob in conjunction with NGF)

THANK YOU

www.electrotherapy.org