

# Acoustic Monitoring of Engine Fuel Injection Based on Adaptive Filtering Techniques

A. Albarbar<sup>1\*</sup>, F. Gu<sup>2</sup>, A. D. Ball<sup>2</sup>A. Starr<sup>3</sup>

<sup>1</sup>*Department of Engineering and Technology,  
Manchester Metropolitan University, Manchester, M1 5GD*

<sup>2</sup>*Computing and Engineering, University of Huddersfield  
Queensgate, Huddersfield, HD1 3DH*

<sup>3</sup>*School of Automotive, Aerospace and Design Engineering,  
University of Hertfordshire, Hatfield, AL10 9AB*

## ABSTRACT

Diesel engines injection process is essential for optimum operation to maintain the design power and torque requirements and to satisfy stricter emissions legislations. In general this process is highly dependent upon the injection pump and fuel injector health. However, extracting such information about the injector condition using needle movements or vibration measurements without affecting its operation is very difficult. It is also very difficult to extract such information using direct air-borne acoustic measurements.

In this work adaptive filtering techniques are employed to enhance diesel fuel injector needle impact excitations contained within the air-borne acoustic signals. Those signals are remotely measured by a condenser microphone located 25 cm away from the injector head, band pass filtered and processed in a personal computer using MatLab. Different injection pressures examined were 250, 240, 230, 220 and 210 bars and fuel injector needle opening and closing impacts in each case were thus revealed in the time-frequency domain using the Wigner-Ville distribution (WVD) technique. The energy of 7 to 15 kHz frequency bands were found to vary according to the injection pressure. The developed enhancement scheme parameters are determined and its consistency in extracting and enhancing signal to noise ratio of injector signatures is examined using simulation and real measured signals; this allows much better condition monitoring information extraction.

## **KEYWORDS**

Condition Monitoring, Internal Combustion Engine (ICE), Fuel Injector, Airborne Acoustics, Adaptive Filtering, Wigner-Ville Distribution (WVD) and Signal to Noise Ratio (SNR).

## **1. INTRODUCTION**

Improvement of diesel engines performance necessities has arisen as a result of the increasing interest in environmental problems, and reduction of noise and pollutant emissions. Fuel injection and the intake management system are one of the key components, which determine engine torque, emissions, noise quality and specific fuel consumption [1, 2, 3, 4]. Injection pressure, fuel quantity, injector opening and closing timings and other parameters are keys to the ideal injection process condition monitoring system. These parameters should be kept at their optimum values to reduce the fuel consumption and pollutant emissions, and increase the output power [2]. Injection induced acoustic signals have been sporadically studied for many years. However, previous work has focused on topics other than the noise radiated from the injector itself. Much of the work in the literature on diesel fuel injection has been devoted to describing the noise and vibration generated by the fuel pumps and fuel lines and radiated by the engine block [3, 5, 6].

In the medium size, high speed diesel engines, the moving mass inside the injector is small in the order of 15 grams, and this mass takes a very short time, in the order of 1-3 milliseconds, from the fully open to fully closed position. As a result, the noise from the diesel injector is a very short click with transient broad frequency content. This noise is radiated from the surface of the injector itself or transmitted through the fuel system or the engine block. There is a distinct opening and closing vibration and noise for most injectors. The opening vibration and noise is due to the moving mass hitting the upper stop and the closing one is due to the moving mass hitting the seat. Unfortunately, the diagnostic signal is dominated by the other sources, corrupted by a background and interference noise. Coherent filtering techniques and adaptive noise cancelling (ANC) could be used to improve the signal to noise ratio of a diagnostic signal. The drawback with these two methods is that the first relies on a synchronizing signal and the second

needs a reference signal which is not always available [7, 8]. In ref. [9] independent Component Analysis (ICA) technique was used to decompose the airborne acoustic signals into their sources and to identify diesel engine noise sources; considerable computations are needed for ICA methods.

In the work reported here, the air-borne acoustic signals were used to monitor injector conditions in acoustically untreated laboratory. Firstly the data was high pass filtered to remove the dominant harmonics and the low frequency bands excited by the room modes. Secondly the adaptive filtering techniques were introduced and the Adaptive Self Tuning scheme was applied to enhance the transient components of a simulated engine airborne acoustic signals. Finally the injector needle impact excitations were enhanced and extracted from real airborne acoustic signals, and the time-frequency domain using the Wigner-Ville Distribution (WVD) was employed to give better localisation for these impacts.

It is evident that the proposed procedure has given clearer results to enhance the injector needle opening and closing impacts excitations. More importantly, SNR improvement allows various statistical methods to be successfully used in diagnosing injector related faults.

Section 2 in this paper gives a review of the engine airborne acoustic signals. The adaptive filtering based schemes are introduced in section 3; results of simulated signals are also presented. The test rig facilities, combustion dependent acoustic signals determination and the exploitation of the proposed scheme in real airborne acoustic data are described in section 4 signals. Section 5 summarises the conclusions.

## **2. ENGINE AIRBORNE ACOUSTIC MODELLING**

The noise from a diesel engine is composed of many components emitted from different sources, see Figure 1. These sources include combustion noise, mechanical noise, and a combination of both. Understanding the components of the acoustic signal is essential to identify the requirements for acoustic signal analysis. Table 1 briefly summarises diesel engine noise excitation forces, their generation mechanisms and noise transmission paths. The combustion noise is produced by the rapid rate of increase of cylinder pressure, which besides being a

source of engine structural vibrations also excites resonances in the gas inside the combustion chamber cavity. The latter is also a source of vibration and noise.

The excitation force, i.e. combustion pressure distorts the engine structure in impulsive manner first. Then the engine structure begins to vibrate as damped free oscillations,  $v(t)$ , in major natural modes. This process is a convolution integral of combustion pressure  $p_c(t)$  and impulse response function  $h(t)$  of the engine structure with acoustic environment included [10, 11].

$$v(t) = \int_{-\infty}^{\infty} p_c(\tau)h(t - \tau)d\tau \quad (1)$$

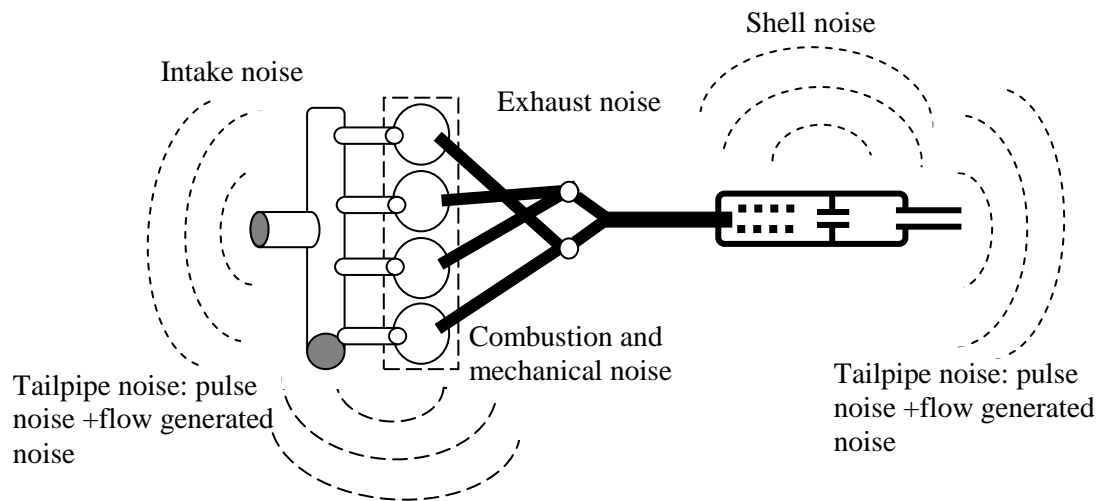

Figure 1 Diesel engine noise sources

Table 1 Excitation forces and their generation mechanism in diesel engines

Excitation Source	Force applied to structure	Vibration Transmission	Noise Emitter
Combustion Excitation	Rapid rate of change in cylinder pressure (pulses)	Cylinder head, Piston and connecting mechanisms	Manifolds covers ICE Block
Mechanical Excitation	Mechanical impact, Piston slap, Bearings, Valves, Injection, Fuel pump	Piston connections and Cylinder walls	ICE Block Sump, Timing Cover.

A rise in the cylinder pressure pushes the piston from the top dead centre (TDC), advancing, to the bottom dead centre (BDC). During this movement, the clearance

between the piston and the cylinder head is small so damage to piston rings or lubrication condition can cause the piston to impact with the cylinder walls; this phenomenon, known as piston slap, is another major source of engine noise. As piston slap occurs on the way from the TDC to BDC, it can be identified by referring to the time or crank shaft angle axis [5]. An important feature of Internal Combustion Engines (ICE) is that they have both reciprocating and rotating parts. Different types of parts will produce different signal components. Rotating parts, such as the flywheel and front pulley, can excite noise with harmonic components. In-cylinder rate of change of pressure is the most important factor generating combustion induced noise. Mechanical noise consists mainly of piston slap impacts, timing gear rattle, bearing impacts, fuel injection system operation, and valve impacts [11].

Based on the above discussion, the microphone output signal  $S(t)$  could be described as Equation 2:

$$S(t) = s_1(t) + s_2(t) + s_3(t) + n(t) \quad (2)$$

Where  $s_1(t)$  represents harmonic narrow band signal components, i.e. tonal signals at frequencies which are integer multiples of the fundamental rotation speed,  $s_2(t)$  is the sum of the incommensurate narrowband components, i.e., non-harmonically related tonal signals,  $s_3(t)$  is the impulsive signals which represents the impacts and impulsive signals and finally  $n(t)$  is the broadband random noise and this component amplitude depends on many factors such as the type of microphone, how far is it from the engine and the room acoustics.

### **3. THE PROPOSED ADAPTIVE SCHEME**

In a situation when there is a spectral overlap between the signal and noise, conventional fixed filters fail and it is necessary for the filter characteristics to be variable so that it can learn to track the signal of interest which is buried in wide-band variable noise. Such filters are defined as adaptive filters.

The adaptive filter is a filter automatically adjusts its coefficients according to the error signal. A particularly interesting class – the self- adapting finite impulse

response filter, usually referred to as simply as adaptive FIR filter (AFIR). The AFIR filter modifies its impulse and frequency response by responding to changes in the filter's output sequence according to some cost function. For example, a signal that is transmitted over a distance may include random noise components, whose spectral power distribution may vary with time. An AFIR filter would continually adjust itself to ensure that the noise bandwidth was minimized in the output signal [12]. There exists a vast array of algorithms for updating the coefficients of the adaptive filter. The most commonly considered is the Least Mean Square (LMS) algorithm for its simplicity.

Figure 2 shows a scheme where the adaptive filter employed as an Adaptive Noise Canceller (ANC); this scheme predicts signals corrupted by additive noise or interference. Two simultaneous input signals are required; the corrupted signal, and the noise that is totally free of the signal of interest, as a reference.

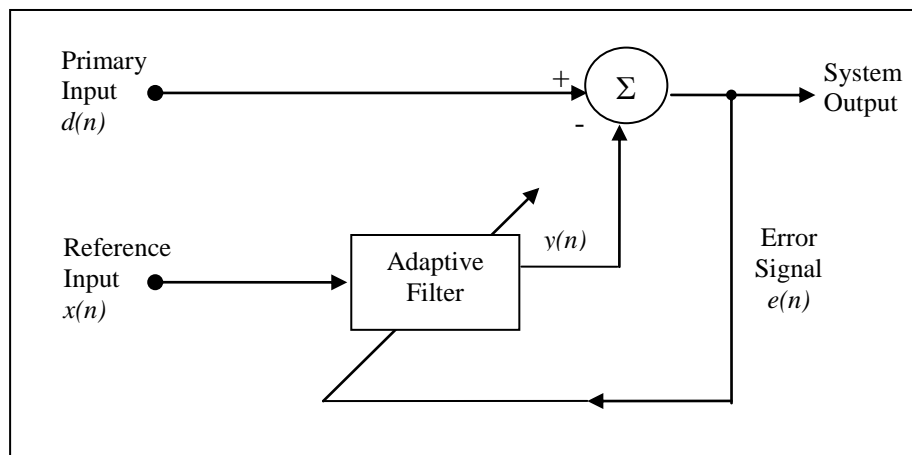

Figure 2 adaptive noise canceller configurations

The reference input is suitably filtered and subtracted from the primary input to obtain the signal estimate. The filtering process is based on the least mean square algorithm,  $d_n$  is the corrupted signal, and  $x_n$  is the noise that is totally free of the signal of interest, as a reference. Another scheme called Adaptive Self Tuning is depicted in Figure 3, this scheme in fact a degenerate form of the adaptive noise canceller in that its reference signal, instead of being derived separately, consists of a delayed version of the input signal [13]. The delay  $D$  is the prediction depth of the AST system, measured in units of sampling period. The reference input

$x_{n-D}$  is processed by a transversal filter to produce an error  $e_n$ , defines as the difference between the actual input  $x(t) + n(t)$  and the AST system output. The error signal is used to actuate the adaptive algorithm through adjusting the weights of the transversal filter.

Most of the adaptive algorithms used in the above schemes are designed according to Widrow's LMS algorithm [14]. The tap weight adaptation of LMS algorithm can be written as

$$w(n+1) = w(n) + \mu x(n)e(n) \quad (3)$$

Where  $w(n)$  is the coefficient vector at time  $n$ ,  $\mu$  is the step size,  $e(n)$  is the adaptation error and  $u(n)$  is the input vector, respectively, at time  $n$ .

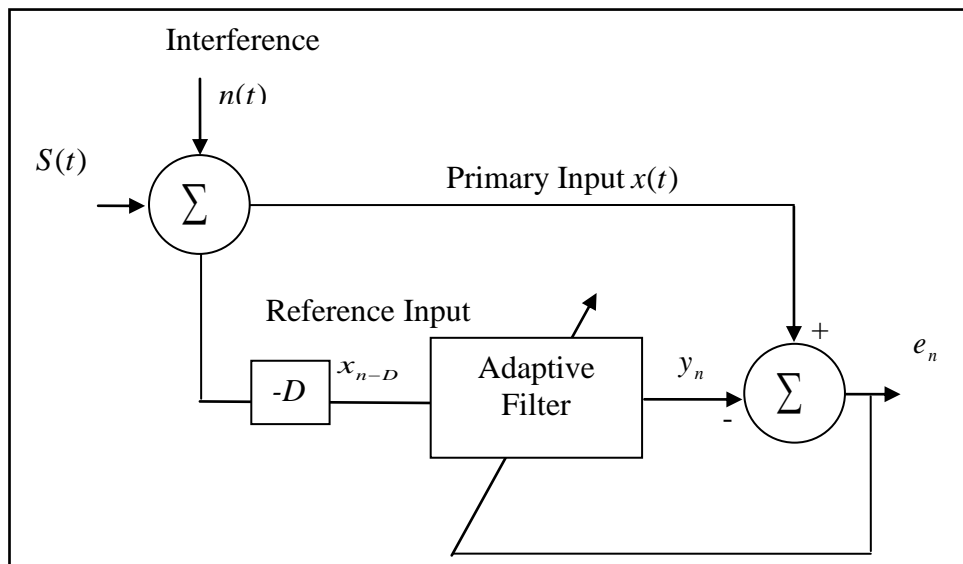

Figure 3 Block diagram of adaptive self tuning scheme

Lee and White used a two stage adaptive line enhancer to enhance the impulsive signals [12]. In their scheme; the first stage employed an LMS algorithm for slow convergence and the second stage used QR-RLS algorithm to quick convergence and it gave good results. Figure 4, shows a simulated engine airborne acoustic signals according to the model in Equation 2. It is very difficult task to extract small transient impact like that induced by the injector needle hitting back seat during opening and hitting its seat while closing. This is because both time and frequency domain of Figure 4, are dominated by the other sources which have

higher energy content. To extract the weak impulsive signals of the impacts an adaptive filtering scheme to enhance the impulsive signals and suppress the other types of signals contained within the measured signal.

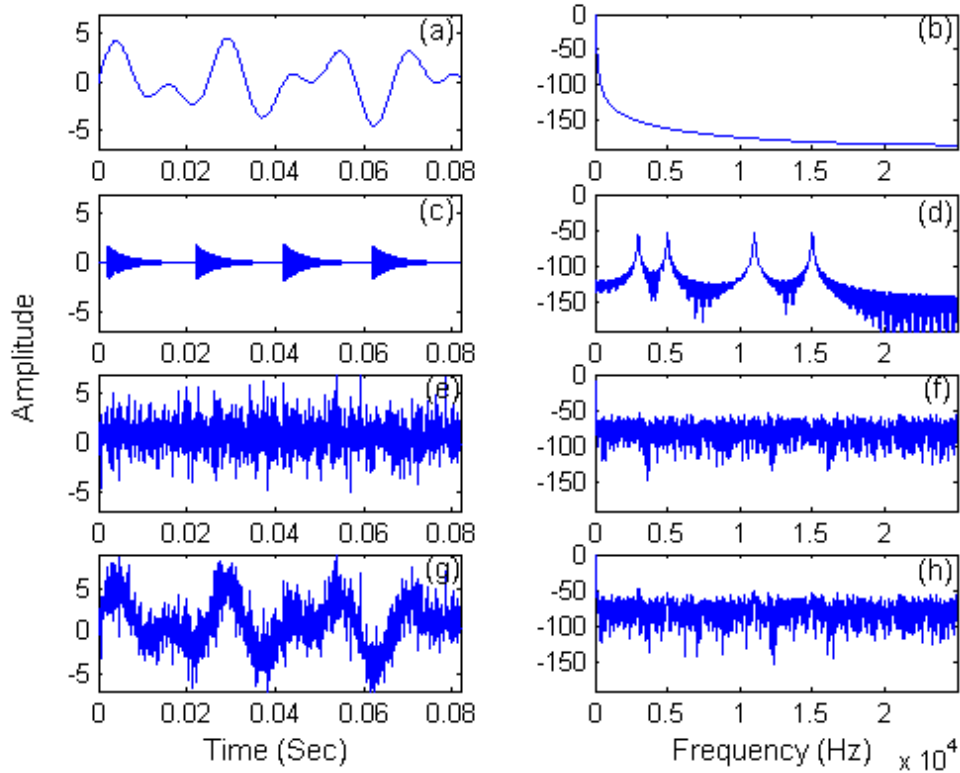

Figure 4 engine airborne acoustics model signal (a) Fundamental firing frequency and harmonics of crankshaft rotation speed; (b) frequency domain of a; (c) four multiple impulsive sounds at 3, 5, 11, 15 kHz; (d) frequency domain of c; (e) broadband Gaussian noise; (f) frequency domain of e; (g) one complete cycle of signal model consists of all the above; (h) frequency domain of g.

The proposed scheme recommended in this paper is shown in Figure 5; two stages of AST are used. The first stage removes the tonal and harmonic components, therefore a long filter length is required to increase the attenuation of the filter at the harmonic frequencies [14]; for this purpose a long LMS algorithm is used. The second stage aims to reduce the broadband noise, for this we need a fast convergence algorithm such as a short Normalised Least Mean Square (NLMS). The above scheme was applied to the simulated airborne acoustic signals shown in Figure 4. The parameters of the proposed scheme were selected as explained above; the step size  $\mu$  was 0.0000005 for the first stage and 0.000005 for the second, the delay D1 was 1 ms and 1 ms for the second. The first stage filter length was 500 and 50 for the second; these parameters satisfy the above criteria.



Figures (6) and (7) show the output signals of the first and the second stages and the associate Fourier transform respectively. Applying the second stage of the scheme eliminated a big portion of the noise and improved the detection of the impulsive signals.

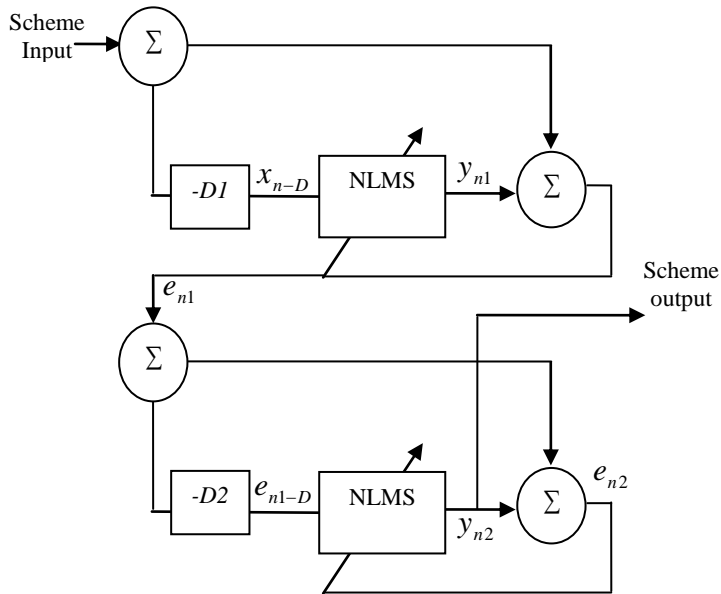

Figure 5 Impulsive impacts proposed enhancement scheme

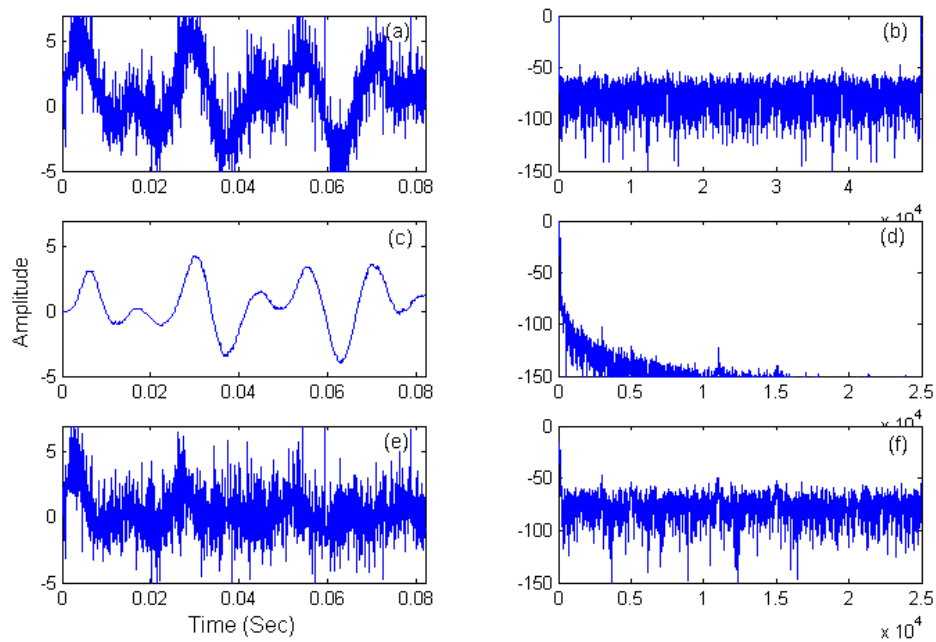

Figure 6 First stage results (a) input signal; (b) Fourier transform of a; (c) first stage output; (d) Fourier transform of c, (e) error signal, (f) Fourier transform of e

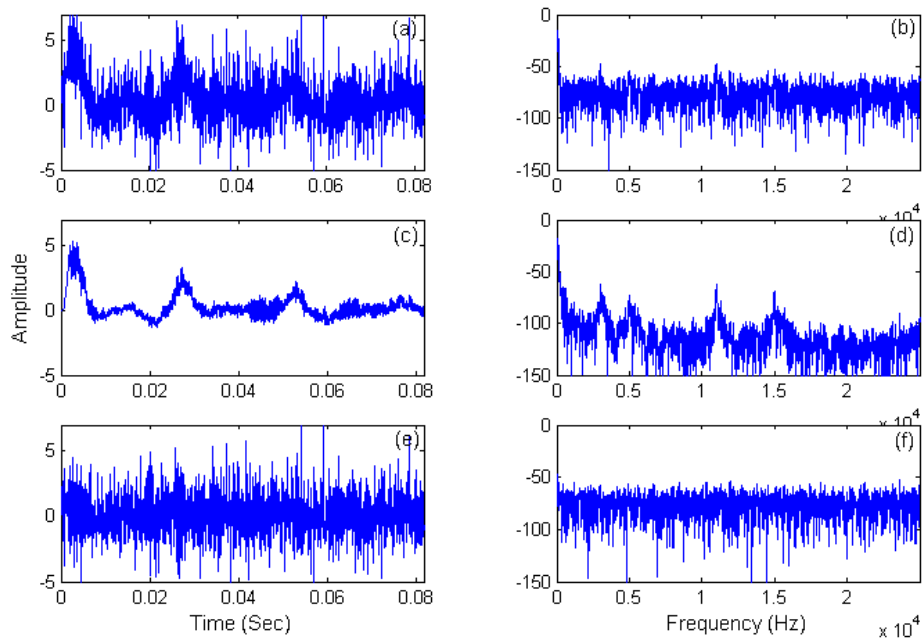

Figure 7 Second stage results (a) input signal; (b) Fourier transform of a; (c) second stage output; (d) Fourier transform of c, (e) error signal, (f) Fourier transform of e.

#### 4. TEST PROCEDURE AND RESULTS

##### 4.1 TEST RIG AND INSTRUMENTATION

The experiments were performed with a four-stroke, four-cylinder, in-line OHV, direct injection, Ford FSD 425 type diesel engine. The schematic diagram for the test rig and instrumentation are shown in Figure 8. Before the pressure sensor and accelerometer signals were fed to the Analogue-to-Digital Converter (ADC), they passed through a B&K type 2635 charge amplifier to condition the signal. The charge amplifier compensates for the reduction in transducer sensitivity due to the use of long cables, filters out unwanted signal components and amplifies the signal. The charge amplifier also converts the high-impedance output signal into a low-impedance voltage signal. Speed and load channels are directly fed to a Cambridge Electronic Design (CED) 1401 Plus multifunctional data collection interface. This ADC has sixteen 12-bit input channels and sixteen digital I/O ports. The in-cylinder pressure signal used to monitor combustion conditions was obtained from a Kistler type 6125A piezoelectric pressure sensor. The flywheel TDC trigger signal is used to set the start time of data collection so that each data segment is measured at an exact crank position. This is to ensure accurate time domain averaging and rearrangement of data segments. The external load is measured with a load cell behind the hydraulic

dynamometer. The air-borne acoustic signals were measured using a high-bandwidth free-field condenser microphone, B&K model MK224, the sampling frequency was set to 80 kHz.

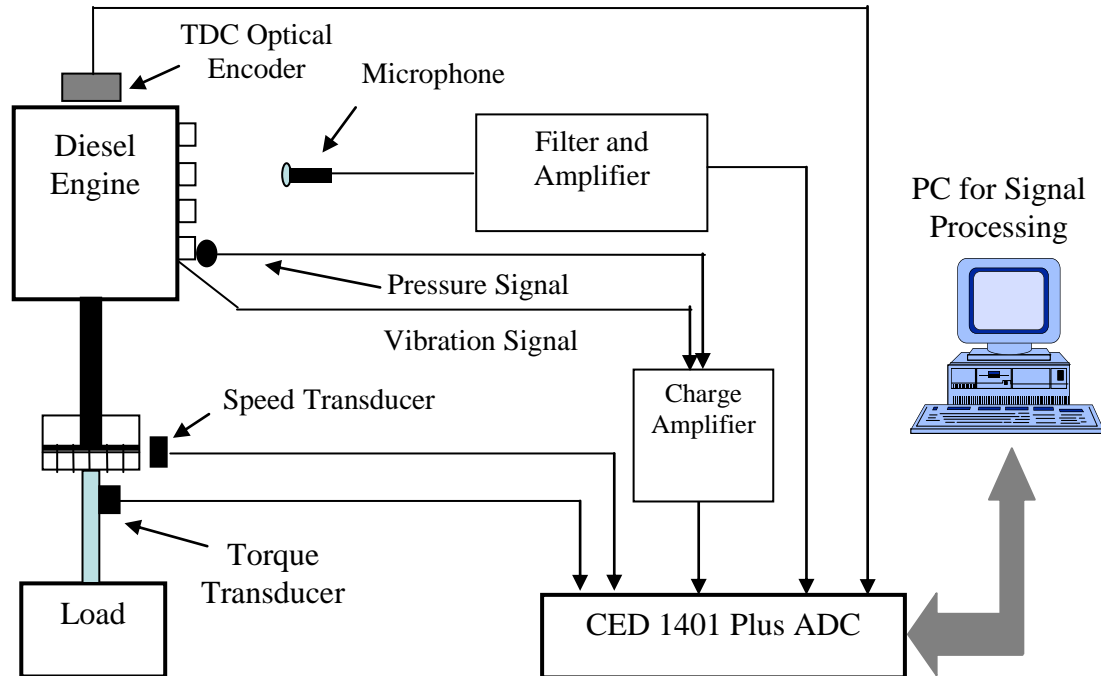

Figure 8 Schematic diagram of engine test system.

#### 4.2 COMBUSTION NOISE DETERMINATION

The pressure in the combustion chamber of a diesel engine has been extensively studied, however to extract weak event; e.g. injection, combustion-induced high-frequency vibration and noise emitted should be precisely determined and filtered out. Figure 9 shows the pressure-crank angle curve for the cylinder pressure in the diesel engine used in this work. If combustion does not occur, then the pressure rises and falls as shown by the curve labelled 'Without firing'. If fuel is injected slightly before top dead centre (TDC), then, after a small delay period, there is rapid combustion during which the pressure quickly rises to a maximum and then falls, see curves labelled 'Firing'. The pressure-crank angle waveform is similar for all curves measured, whether on full load, part load or no load and with or without firing [6]. The rapid rise in pressure generates high-frequency components in the excitation force, as shown in Figure 10. This figure shows the increase in amplitude of the frequency components of excitation above about 250Hz, when combustion takes place. Clearly, these high frequency components contain information about the

combustion process, particularly its onset and rate of rise. The spectrum of the cylinder pressure initially drops off rapidly, about 40dB per octave, and thus contains little high-frequency energy. The shape of the cylinder pressure curve is similar whether there is firing with no load, some load or high load, the difference being the brief period of rapid pressure rise due to combustion, thus it can be inferred that the increase in high-frequency (above 250Hz) energy when combustion takes place is due to this rapid increase in pressure when the piston is approaching TDC, after the fuel has been injected [6].

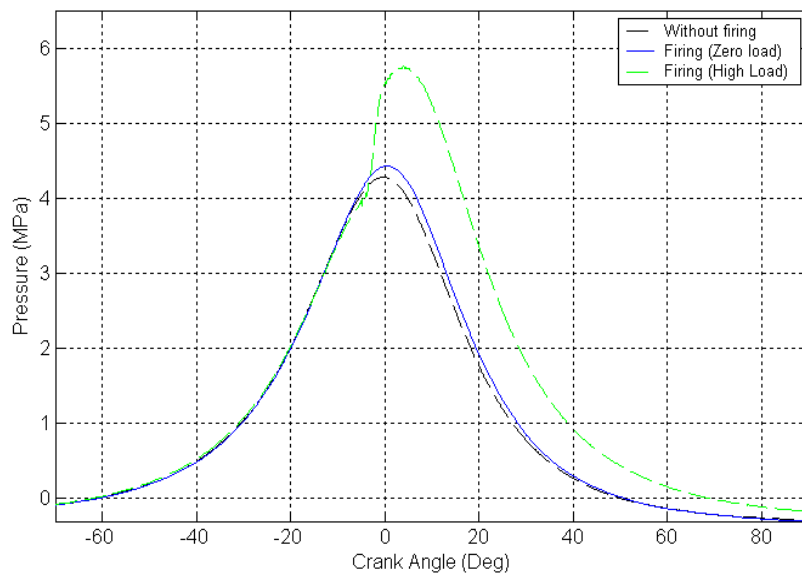

Figure 9 Engine cylinder pressure vs. crank angle ( $0^{\circ}$  = TDC)

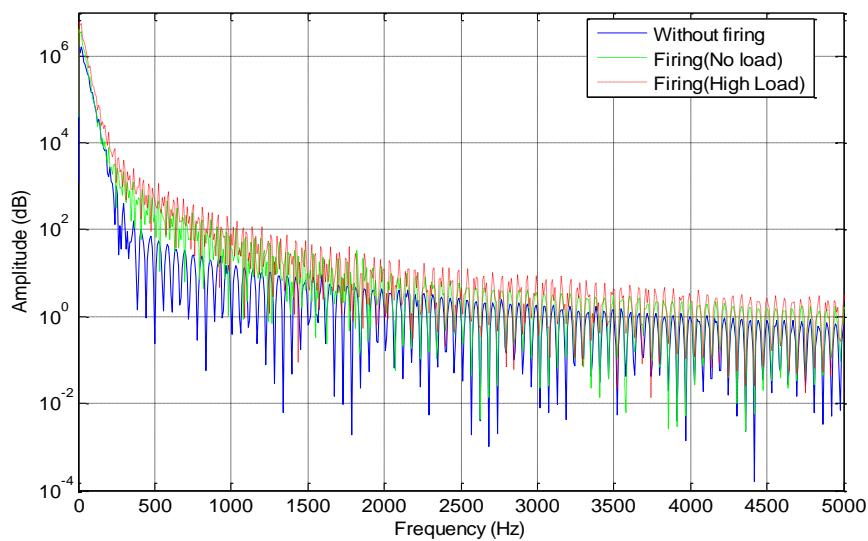

Figure 10 Spectrum of cylinder pressure

### 4.3 SIGNAL PROCESSING AND FEATURES EXTRACTION

A sample of signals of interest is shown in Figure 11. In Figure 11(a) cylinder pressure and injector line pressure are overlaid. As expected the injector pressure drops just before the onset of combustion, around  $5^\circ$  before TDC ( $0^\circ$  crank angle). The induced vibration and air-borne acoustic signals for two complete revolutions ( $720^\circ$ ) of the crank shaft are displayed in Figure 11(b). What makes the waveform complicated and difficult to extract information from is the numerous frequency components superimposed on each other [6].

To show the effectiveness of the proposed scheme in detecting injector opening and closing angles; only those parts around TDC are displayed in the following figures. Figure 11(a) and (b) show injector vibration and airborne acoustic signals respectively, (b) and (d) show the associated WVD time-frequency representations. The vibration WVD time-frequency representation shows the injection beginning and ending with excitations between 7 and 15 kHz; this was proved by the authors in references 3 and 4. However the airborne acoustic signal is dominated by combustion and background noise.

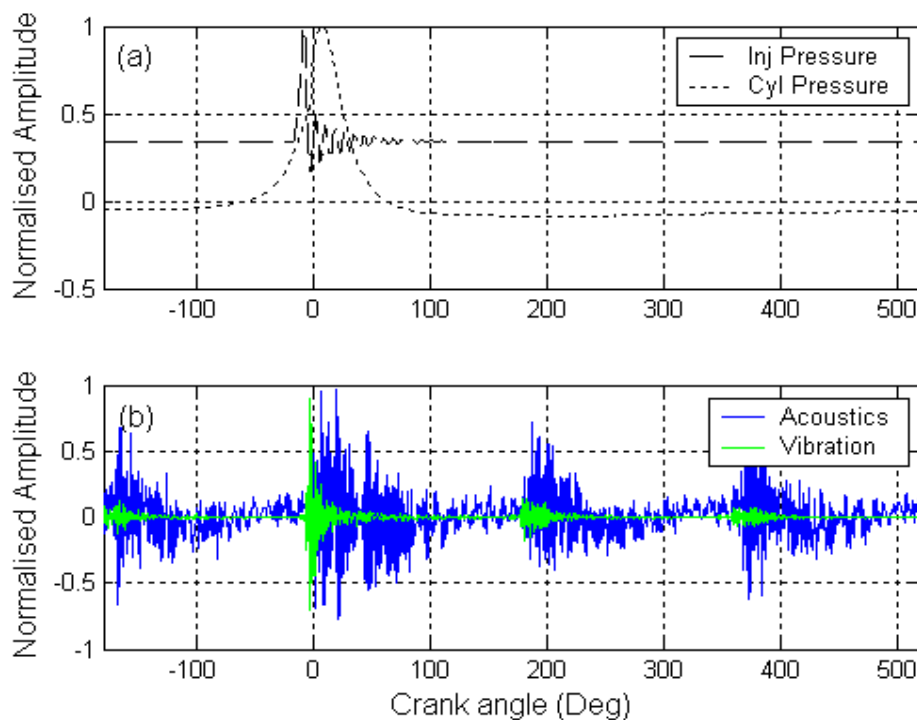

Figure 11 collected data; (a) normalised cylinder pressure, and fuel line pressure (b) normalised engine air-borne acoustics versus injector body vibration.

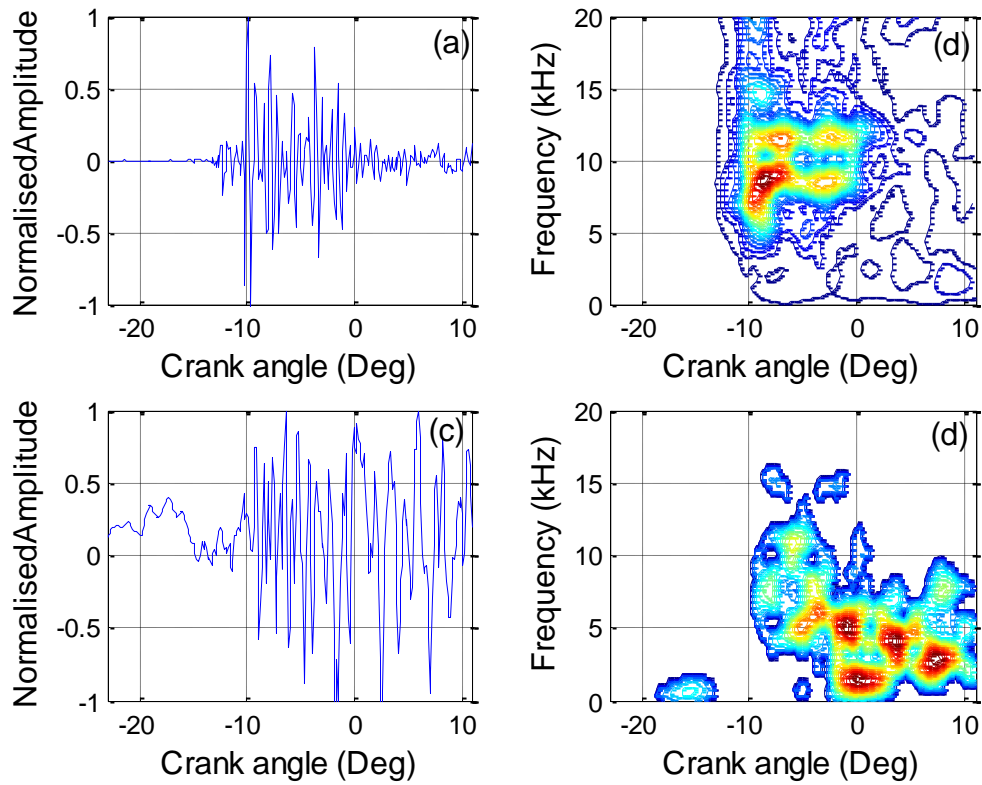

Figure 12 Airborne acoustics and vibration data, (a) normalised injector vibration, (b) WVD of (a), (c) normalised injector air-borne acoustics, and (d) WVD of (c).

To extract the injector operation impacts from the monitored airborne acoustic signals using the proposed adaptive scheme, the dominant harmonic components were removed using a high pass filter and the residual signal was used as an input to the proposed adaptive scheme. Figure 13 and 14 show the outputs of the two stages when the engine running at 1000 rpm under no load and under high load (60 Nm) respectively.

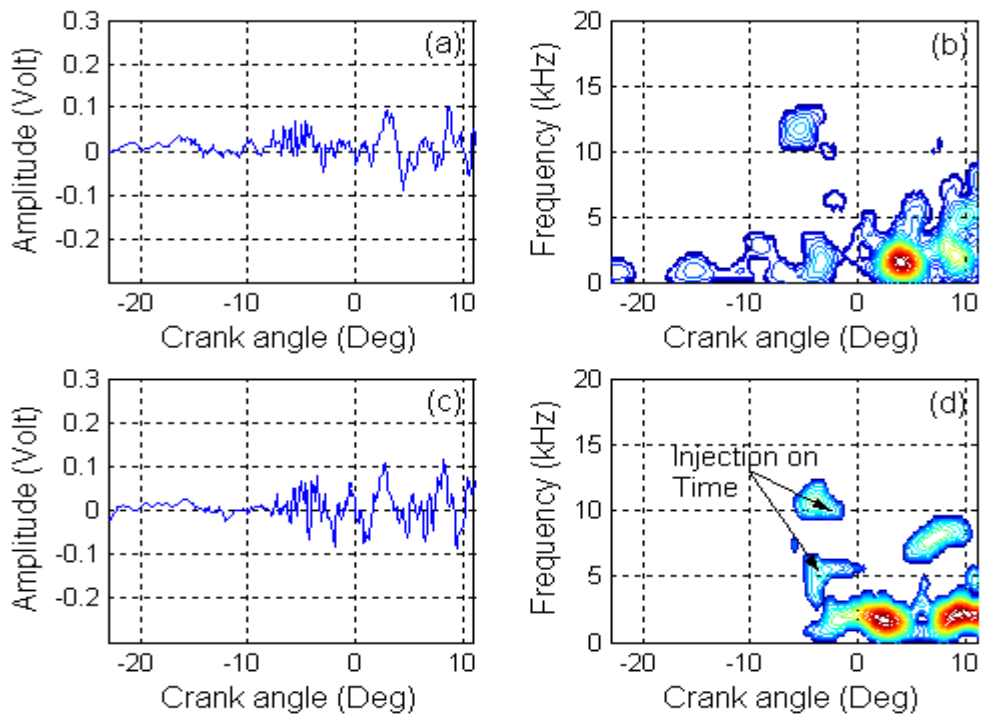

Figure 13 Airborne acoustic signal for healthy engine under no load running at 1000 r/m, (a) first stage output, (b) WVD of (a), (c) second stage output, and (d) WVD of (c).

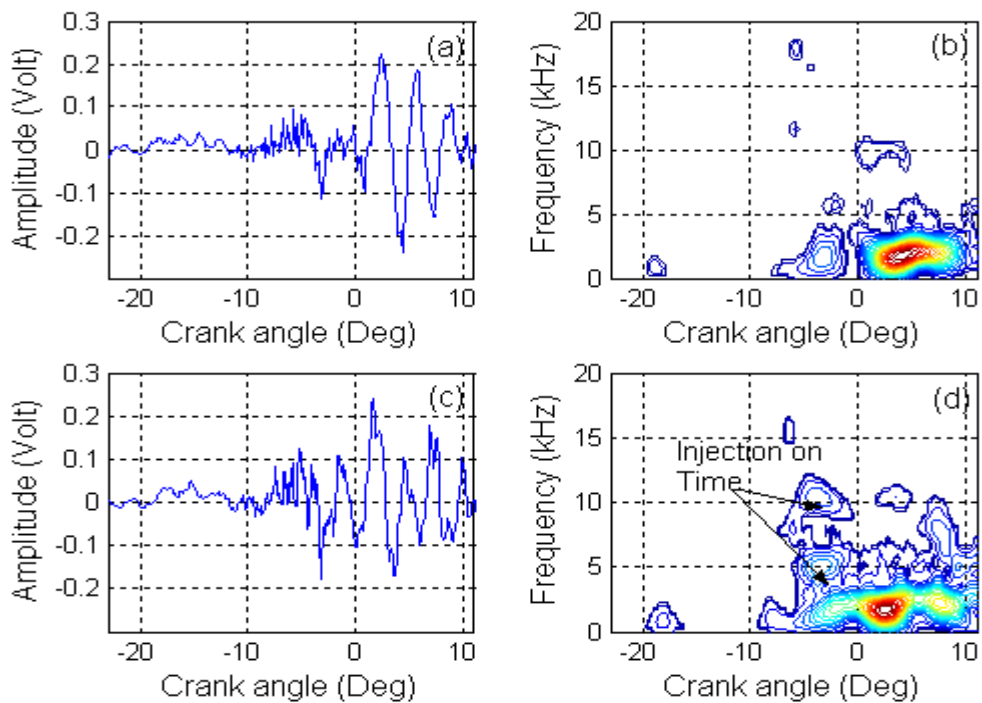

Figure 14 Airborne acoustic signal for healthy engine under high load running at 1000 r/m, (a) first stage output, (b) WVD of (a), (c) second stage output, and (d) WVD of (c).

From the Figure 13(d), the impacts around  $5^\circ$  before TDC which represent the injection process events [16] were enhanced and made clearer. By increasing the load more fuel is injected and stronger impacts are expected, as shown in Figure 14(d). One of the most important parameters defining injector condition is the stiffness of the injector spring holding the needle onto its seat. Any decrease in the stiffness will change the injection time and therefore degrade the combustion process and the engine performance. As fault simulation; the stiffness of the injector spring for cylinder number 1 was reduced and therefore the injection pressure decreased. In this case the opening pressure of the healthy injector was 250 bars and by reducing the spring stiffness the injector opening pressure was reduced to 230 bars. As a result earlier injection was expected. The beginning and ending time of the injection, which is represented by signal transient components generated by impacts between the needle and seat/backstop can be found from the WVD time-frequency representations.

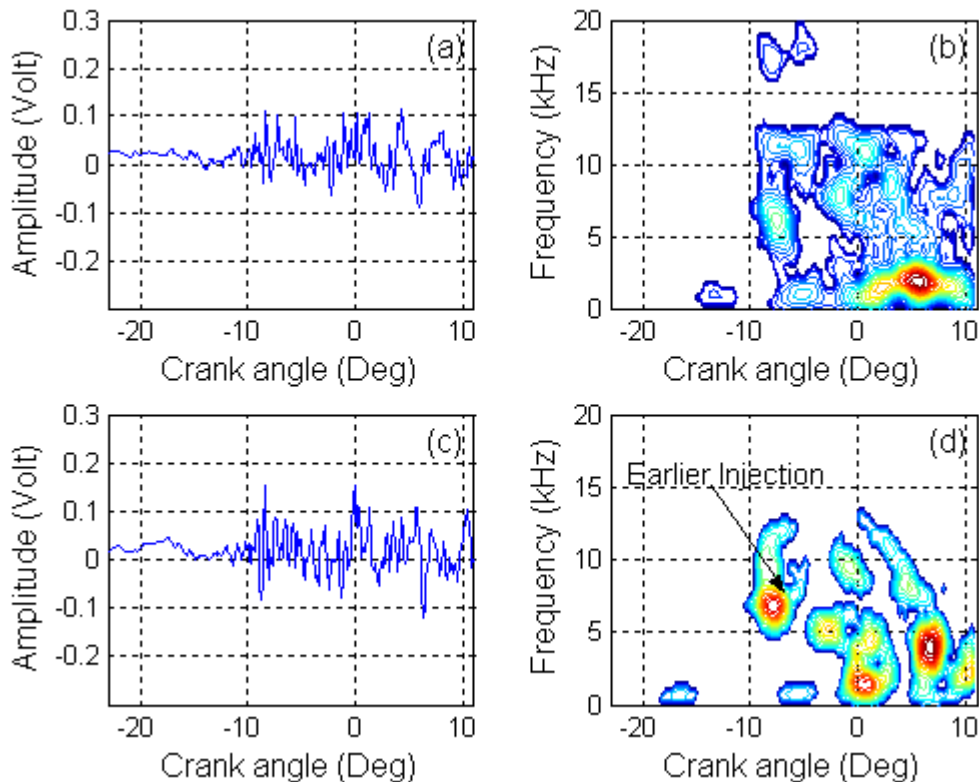

Figure 15 Injector pressure reduced to 230 bar, airborne acoustics under no load running at 1000 r/m, (a) first stage output, (b) WVD of (a), (c) second stage output, and (d) WVD of (c).



Figures 15 and 16 show the outputs of the two stages with the engine running at 1000rpm under no load and under high load respectively. The injection time is brought forward around  $3^\circ$  and with greater impact between the needle and seat/backstop [3, 4]; Figure 15(d). These observations become clearer under high load, Figure 16(d).

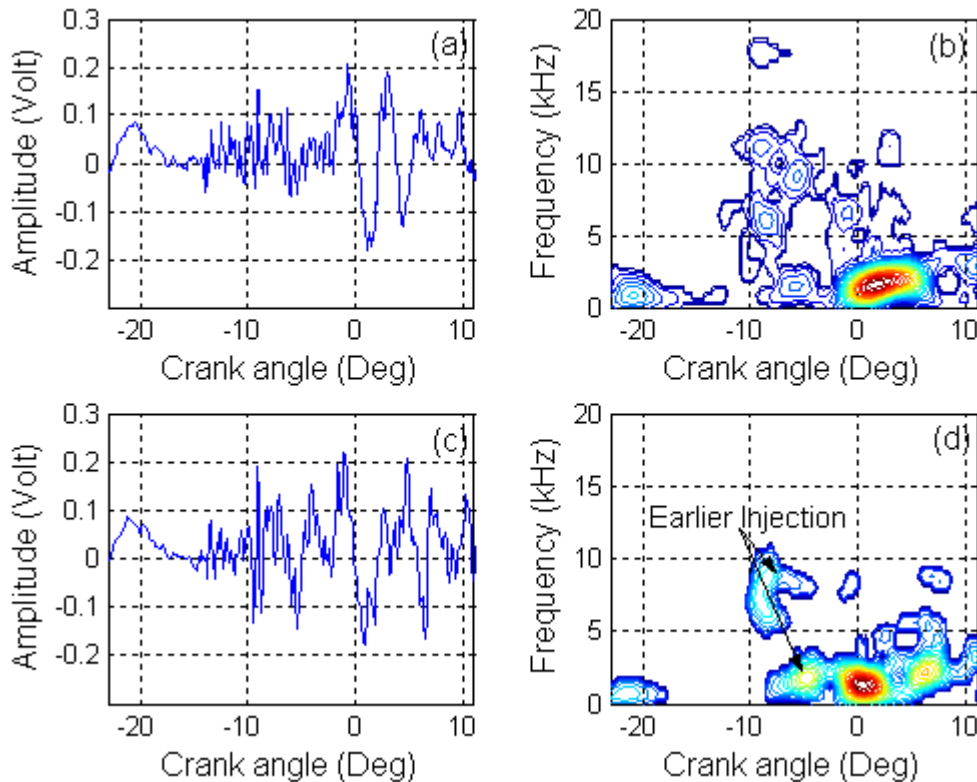

Figure 16 Injector pressure reduced to 230 bar airborne acoustics under high load running at 1000 r/m, (a) first stage output, (b) WVD of (a), (c) second stage output, and (d) WVD of (c).

Figure 17 shows normalised energy statistical results of the output of the second stage at 60 Nm load and 1000, 1500 and 2000 r/m engine speeds; these energy quantitative results were calculated within a rectangular area around the injection event from  $15^\circ$  BTDC to  $3^\circ$  BTDC. It can be seen clearly that the energy levels decrease as the injector opening pressure decrease and this becomes clearer at higher speeds. When the opening pressure reduced to 210 bars the impacts normalised energy decreases 15% at 2000 r/m compared with 7% reduction at 1500 and 3% at 1000 r/m.

Similar results were obtained under different speeds and loads of 40, 30 and 20 N.m; as shown in Figure 18.

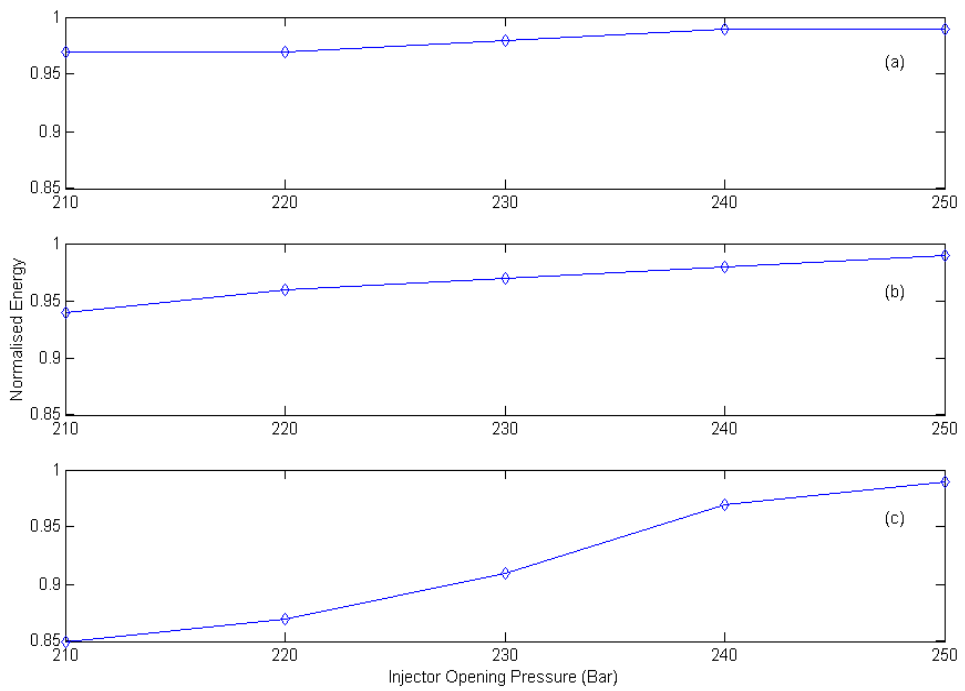

Figure 17 Effect of change in injection pressure, normalised energy comparison at 60 Nm load and speeds of (a) 1000 r/m, (b) 1500 r/m, and (c) 2000 r/m

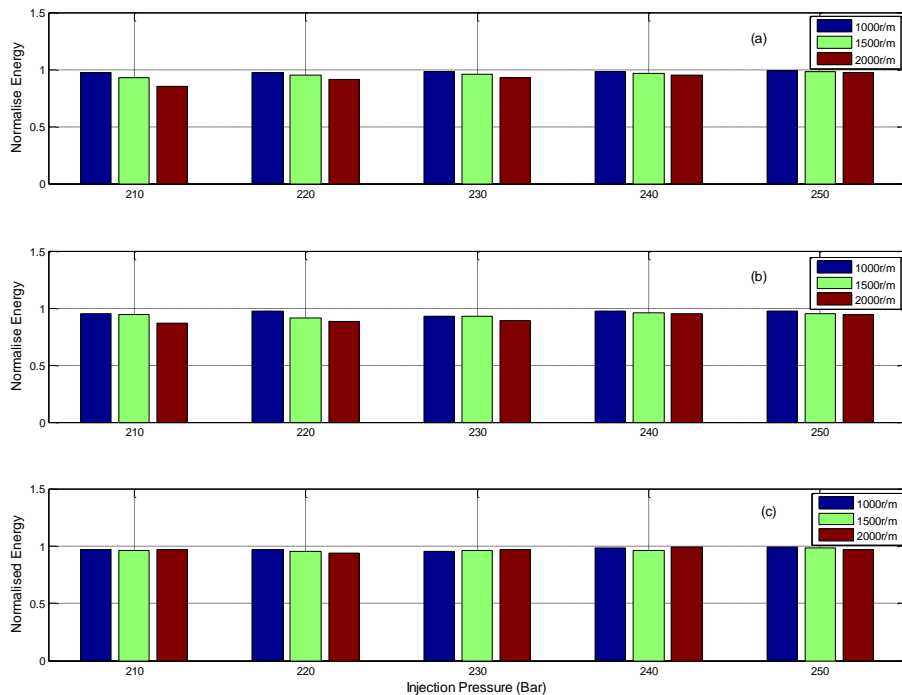

Figure 18 Effect of change in injection pressure, normalised energy comparison at different speeds and loads of (a) 40, (b) 30, and (c) 20 N.m.

## 5. CONCLUSIONS

The adaptive filtering based scheme presented in this work shows promising results in detecting and diagnosing injection pressure faults. This technique was employed for the enhancement of diesel common hole injector events extraction. The following few conclusions could be highlighted:

- a. Diesel engine acoustic signals time domain extracted features, spectral analysis and statistical parameters give limited information. The frequency domain analysis gives only information about the frequency components of the measured signals and in the case of diesel engine acoustic condition monitoring these frequency components are dominated by the firing frequencies of the engine and its harmonics.
- b. The low frequency band (below 5 kHz) is dominated by the combustion induced noise and it is difficult to detect any other acoustic sources such as injection process induced acoustic signals, exhaust and intake valve acoustic sources. Therefore these dominating frequency bands should be carefully filtered.
- c. The proposed two stages adaptive scheme parameters selection criteria were determined; the delay of both stages are the same, however the second stage step size is 10 times first stage and the first stage filter length is 10 times the second.
- d. The approaches introduced in this article proved to be excellent in detecting small changes in the injector default settings; which make it good on-line condition monitoring tool. The achieved results are promising and proven to work quiet well at low and high speeds especially under high loads and high speeds; 60 Nm and 2000 r/m. The adaptive scheme developed in this work show promising results in detecting and diagnosing injector pressure.
- e. The proposed scheme could be useful in defining and enhancing other impulsive events within the airborne acoustic signals such as intake and exhaust valves operation and piston slap excitations. It also offers

diagnosticians better tool for condition monitoring of other rotating machinery such as gearboxes and pumps.

## REFERENCES

1. A. Parlak, H. Yasar, C. Hasimoglu, A. Kolip. *The effects of Injection Timing on NOx Emissions of a Low Heat Rejection Indirect Diesel Injection Engine. Applied Thermal Engineering, Volume 25, 2005, 3042-3052.*
2. K. Purushothaman, G. Nagarajan *Effect of Injection Pressure on Heat Release Rate and Emissions in CI Engine Using Orange Skin Powder Diesel Solution Energy Conversion and Management 2009. 50: p 962–969.*
3. F. Gu, A. D. Ball, *Diesel Injector Dynamics and Estimation Injection Parameters from Impact Response. Part 1: Modelling and Analysis of Injector Impacts. Proc Institution of Mechanical Engineers. Proc. Inst. Mech. Eng., Part D (J. Automob. Eng.) 1995, Vol. 210, pp. 293-302*
4. F. Gu, A. D. Ball, *Diesel Injector Dynamics and Estimation Injection Parameters from Impact Response. Part 2: Prediction of Injection Parameters from Monitored Vibration. Proc Institution of Mechanical Engineers. Proc. Inst. Mech. Eng., Part D (J. Automob. Eng.) 1995, Vol. 210, pp. 303-312.*
5. A. Albarbar, F. Gu, A. Ball, A. Starr, *Internal Combustion Engine Lubricating Oil Condition Monitoring Based on Vibro-acoustic Measurements. Journal of Non Destructive Testing Institution. 2007, 49:p.715-719.*
6. A. Albarbar, F. Gu, A. Ball, A. Starr, *On Acoustic Measurement Based Internal Combustion Engines Condition Monitoring. Journal of Non-destructive Testing Institution. Insight, 2008, 50:p. 30-34.*
7. A. Albarbar, S. Alhashmi, R. Gennish, F. Gu, and A. D. Ball, (2004) ‘Adaptive Noise Cancelling for Enhancing Diesel Engine Air-Borne Acoustic Signal to Noise Ratio’. *The 17<sup>th</sup> International Congress & Exhibition on Condition Monitoring And Diagnostic Engineering Management COMADEM 2004 International, Cambridge, UK.*
8. A. Albarbar, R. Gennish, F. Gu, and A. D. Ball, *Diesel Engine Injector Condition Monitoring Using Air-Borne Acoustics. The International Congress in Mechatronics, 2004 International, Ankara, Turkey, 2004.*
9. W. Li., F. Gu., A.D. Ball, A.Y. Leung, and C.E. Phipps. *A Study of the Noise from Diesel Engines Using the Independent Component Analysis. Mechanical Systems and Signal Processing (2001) 15(6), 1165-11.*
10. M. Ishihama, *Improving Diesel Engine Noise and Vibration Assisted by Time Domain Subjective Evaluation Technique, Kanagawa Institute of Technology, Atsugi, Japan. 1997.*
11. T. Priede, *In Search of Engine Noise a Historical Review. SAE paper, 1980, 800534, 2039-2069.*
12. S. Haykin, *Adaptive Filter Theory. New Jersey: Prentice-Hall; 2002, ISBN 978-0-12-374538-5.*

13. S. Lee, P. White, *The Enhancement of Impulsive Noise and Vibration Signals for Fault Detection in Rotating and Reciprocating Machinery*, *Journal of Sound and Vibration*, 1998 217( 3):p 485-505
14. B. Widrow, S. Stearns, *Adaptive Signal Processing*. New Jersey: Prentice-Hall; 1985.
15. J. Zeidler, E. Satorius, D. Chabries and H. Wexler, *Adaptive Enhancement of Multiple Sinusoids in Uncorrelated Noise*, *IEEE Transactions on Acoustics, Speech and Signal Processing*, 1987( 26):p 240-254.
16. Ford Motor Company, *FSD 425 engine service manual*. England. Essex 1994.
17. V. Marples., *The frequency content of the surface Vibration of diesel engine*. *Journal of Sound and Vibration*, 1977. 52(3): p. 365- 386.