

Review article



AI-based energy management strategies for electric vehicles: Challenges and future directions

Azadeh Kermansaravi^{a,*}, Shady S. Refaat^b, Mohamed Trabelsi^c, Hani Vahedi^a 

^a Delft University of Technology, Delft, Netherlands

^b School of Physics Engineering and Computer Science, University of Hertfordshire, United Kingdom

^c Electronics and Communications Engineering Department, Kuwait College of Science and Technology, Kuwait

ARTICLE INFO

Keywords:

Artificial intelligence
Battery management
Charging strategy
Energy management systems
Electric vehicles

ABSTRACT

Electric vehicles (EVs) offer a promising solution for mitigating greenhouse gas emissions and minimizing the transportation sector's dependency on non-renewable energy sources. However, efficient energy management poses a significant challenge for their broader adoption, particularly optimizing battery usage, maximizing driving range, and improving overall vehicle performance. This paper presents the state-of-the-art Artificial Intelligence (AI) techniques used in electric vehicle energy management systems (EV-EMS), discussing a variety of deep learning algorithms of AI methodologies, such as , neural networks, and fuzzy logic. Additionally, This paper discusses the role of auxiliary techniques like transfer learning, which enhances model adaptability and reduces training time in AI-driven EMS applications. Through a systematic analysis of each method, this review identifies key trends, highlights the challenges and limitations of each technique, and offers perspectives on potential solutions and future research directions. The paper aims to support researchers, industry professionals, and policymakers in developing advanced, sustainable, and adaptable EV-EMS solutions that maximize battery life, improve vehicle performance, and facilitate real-time adaptive control. Finally, this review highlights the importance of AI-driven strategies in making EV technology more efficient, reliable, and scalable.

1. Introduction

The transportation sector significantly contributes to global carbon emissions, highlighting the need for cleaner and more sustainable alternatives. EVs have emerged as a promising solution for reducing environmental degradation and dependence on fossil fuels. However, EV success depends on charging infrastructure and grid integration and, on efficient internal EMS to optimize performance and energy use.

While internal and external energy management strategies play important roles in EV operations, this paper focuses on internal EMS for pure EVs, which control energy flow among the vehicle's elements, ensuring that power from the battery and regenerative braking systems is utilized efficiently. This paper considers external energy management approaches, such as vehicle-to-grid (V2G) and grid-to-vehicle (G2V) interactions, where applicable. Nevertheless, it focuses on optimizing in-vehicle power distribution, not grid operations.

Effective energy management strategies in EVs are critical for optimizing internal energy distribution, enhancing vehicle performance, minimizing power loss, and enabling border sustainability objectives such as reducing grid stress and integrating renewable energy sources.

These strategies' primary goals are optimizing overall efficiency and ensuring the smooth operation of the vehicle's power system. The primary goals are minimization of power loss, controlling voltage fluctuations, peak load reduction, and energy cost minimization.

External energy management systems for electric vehicles enhance the coordination between the power grid, renewable energy sources, and other external systems. Recent advancements include employing distributed control and blockchain technologies for dynamic load balancing and efficient energy distribution. For example, V2G and G2V technologies enable bidirectional power flow, which balances demand from the grid and lowers energy costs. Moreover, using renewable energy sources like solar-powered charging stations contributes to enhanced sustainability. These actions deliver grid reliability, suppress peak demand, and encourage the utilization of renewable energy (Hu et al., 2022; Hu and Li, 2021; Ma et al., 2024).

This paper addresses internal EMS challenges in EVs, including battery optimization, energy efficiency, and real-time power flow management. While external energy interactions are acknowledged where relevant (e.g., their impact on in-vehicle charging strategies), the focus

* Corresponding author.

E-mail addresses: z.kermansaravi@tudelft.nl (A. Kermansaravi), s.khalil3@herts.ac.uk (S.S. Refaat), m.trabelsi@kcst.edu.kw (M. Trabelsi), h.vahedi@tudelft.nl (H. Vahedi).

<https://doi.org/10.1016/j.egy.2025.04.053>

Received 20 January 2025; Received in revised form 23 March 2025; Accepted 24 April 2025

Available online 13 May 2025

2352-4847/© 2025 The Authors. Published by Elsevier Ltd. This is an open access article under the CC BY license (<http://creativecommons.org/licenses/by/4.0/>).

remains on in-vehicle energy distribution rather than external grid optimization.

Internal energy management in EVs is naturally complex due to several challenges, including the dynamic nature of driving conditions, variability in power demand from different vehicle subsystems, the need to balance energy from diverse sources, and balancing energy distribution to maintain high efficiency while extending the battery lifespan. The EMS within an EV must effectively control the power flow between the battery, powertrain, and auxiliary components, adapting in real-time to optimize the performance and life of the battery. This kind of balance is particularly challenging with frequent changes in driving patterns, acceleration, and regenerative braking, where high energy efficiency is essential. A next-generation electric vehicle with in-wheel motor technology enhances system efficiency by eliminating mechanical intermediaries and optimizing regenerative braking. The two-stage predictive controller improves vehicle mileage by over 24% while managing key constraints like battery health and safety (Tie and Tan, 2013, 2012; Salari et al., 2023; Mastoi et al., 2022).

Uncontrolled energy management approaches, commonly known as “dumb charging”, often consider user convenience over system efficiency. This approach of plug-and-charge allows for immediate charging without regulating power flow based on vehicle demand or grid conditions. This method manages the timing of the charging process based on reliance on time-of-use (TOU), leading to potential overloading of the distribution system. High penetration levels for uncontrolled EV charging can also exceed the network capacity, causing load imbalance and potential power quality issues. Despite these drawbacks, uncontrolled charging remains popular among EV users due to its simplicity and flexibility (Upadhyaya and Mahanta, 2023; Katkar and Goswami, 2020).

In contrast, intelligent or “smart” internal energy management strategies leverage advanced control systems to optimize the charging and discharging cycles of the vehicle. These strategies cover both the timing and power levels to mitigate the likelihood of system overloading and congestion and improve energy distribution. Moreover, intelligent EMS supports various energy management applications such as G2V, V2G, and vehicle-to-home (V2H), enhancing both economic and environmental outcomes.

Although some EMS strategies interact with external power sources (e.g., V2G, G2V, V2H), this paper primarily focuses on in-vehicle decision-making for energy allocation, ensuring that AI-driven solutions optimize power distribution at the vehicle level.

AI techniques are increasingly being used for their potential to address these challenges by enabling advanced energy management strategies tailored to the dynamic nature of EV operation. By incorporating machine learning, neural networks, and predictive analytics, AI can dynamically adjust energy usage to suit varying driving conditions, user preferences, and external factors such as temperature or terrain. Existing literature includes numerous reviews of recent advances in internal energy management systems schemes for EVs. In comparison to the previous studies, this paper offers a comprehensive and up-to-date overview and comparison of qualitative and quantitative AI-based energy management strategies, making a detailed analysis of the current research landscape. The paper aims to identify key trends, challenges, and opportunities for future research, offering valuable insights for policymakers, industry professionals, and researchers.

By concentrating on internal EMS, this study directly addresses the critical challenges EVs face, such as optimizing battery performance, reducing internal power losses, and improving real-time energy allocation. This emphasis aligns to make EVs more efficient, reliable, and widely adopted.

The paper is organized as follows: Section 2 reviews prior research studies on both internal and external energy management methodologies. Section 3 offers an overview of the AI techniques employed in EV energy management systems. Section 4 examines various EMS strategies, emphasizing their role in optimizing internal energy distribution and enhancing vehicle performance. Finally, Section 5 summarizes the essential findings and outlines potential future research directions.

2. Background

Over the past decade, there has been a significant interest in the research of energy management strategies for EVs. The reason behind such an increase in interest is the necessity to address the challenges related to the limited availability of oil resources and environmental concerns resulting from emissions from ICEs. The transition to EVs is an essential step toward sustainable transportation, offering benefits such as reduced greenhouse gas emissions, improved energy efficiency, and enhanced vehicle performance. However, a significant challenge for electric cars relies on optimizing energy usage within EVs, especially in extending the battery life, minimizing power losses, and ensuring efficient power distribution to various subsystems

An effective EMS balances energy consumption among the vehicle’s powertrain, auxiliary systems, and energy storage units. The EMS must dynamically distribute power in real-time based on demand and driving patterns, making it a complex optimization problem that requires sophisticated control strategies. Uncontrolled energy management in the form of instant and unregulated charging and discharging is responsible for inefficient energy use, battery degradation, and reduced driving range (Suhail et al., 2021).

Understanding the dynamics between vehicle subsystems is crucial in designing efficient internal EMS for EVs. Fig. 1 illustrates the structural framework of the internal energy distribution in EVs, highlighting the main components and their interrelations. This layout highlights the intricacy of energy flow among battery, powertrain, and auxiliary systems that must be dynamically controlled to meet variable power demands while optimizing energy consumption. The figure presents the requirement for advanced control algorithms to manage the energy distribution efficiently, thereby ensuring enhanced performance and extended battery life under various driving conditions.

Over the past few years, various machine learning techniques have been applied to EV-EMS, offering innovative solutions to optimize energy usage and enhance vehicle performance. As illustrated in Fig. 2, these techniques are broadly categorized into reinforcement learning, semi-supervised learning, unsupervised learning, and supervised learning, each of which tackles the EV energy optimization problem differently. Reinforcement learning, which comprises policy-iteration-based and value-iteration-based approaches, excels at real-time adaptive decision making for EV charging and energy distribution tasks. Semi-supervised learning techniques, e.g. hybrid models, pseudo-labeling, graph-based models, consistency regularization, and generative models, apply both labeled and unlabeled data to enhance accuracy while reducing the reliance on big labeled datasets. Unsupervised learning techniques, such as clustering, dimensionality reduction, and density estimation, uncover hidden patterns in the data, facilitating optimized energy usage without labels. On the other hand, supervised learning, focusing on classification and regression, predicts essential parameters like state-of-charge (SoC), energy consumption, and driving range. Fig. 2 categorically classifies these techniques, presenting their roles in improving energy efficiency, extending battery life, and guaranteeing efficient energy distribution in EVs.

Several studies have introduced novel approaches to energy management in EVs, categorizing them into two broad categories: external EMS that maximize power grid interactions and internal EMS for efficient utilization of energy within the vehicle itself.

Abdullah et al. (2021) provided a comprehensive review of reinforcement learning (RL)-based models, objectives, and architectures for EV charging coordination approaches in power systems. The study presented a detailed comparative analysis of various charging coordination approaches under a number of constraints with special application to the design of optimized internal energy management systems for EV charging. The paper also highlighted the contribution of RL towards stimulating research and development efforts in creating efficient energy management systems, offering valuable context and guidance for researchers working on EV charging schedule optimization problems.

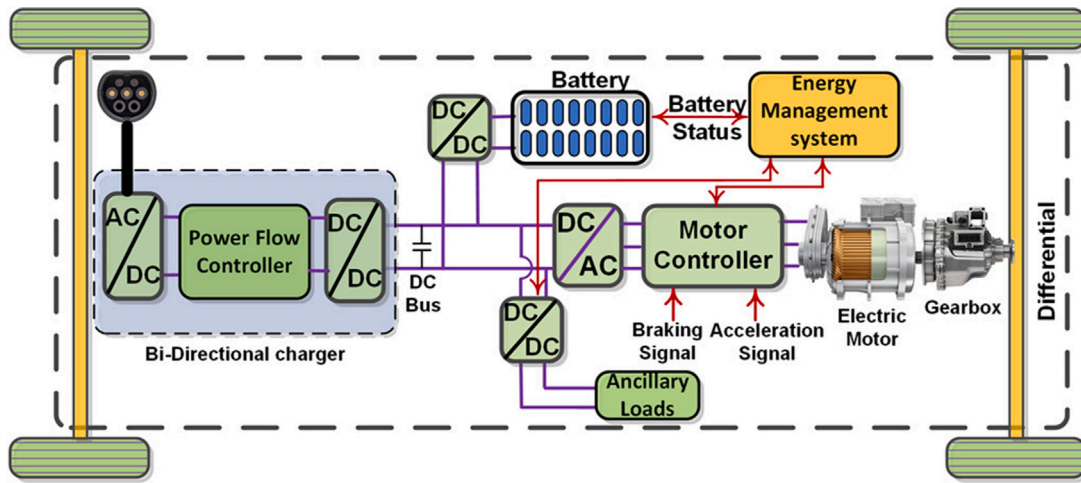

Fig. 1. Schematic representation of internal energy distribution in EVs.

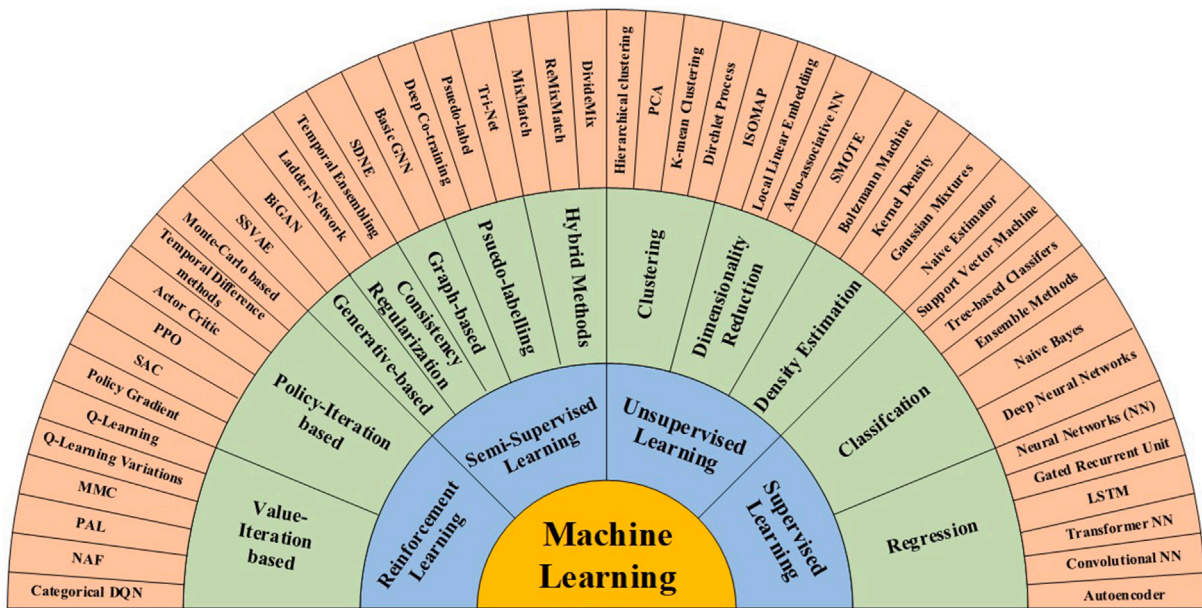

Fig. 2. Classification of machine learning techniques utilized in EV energy management systems (EV EMS).

The main drawback of this study is that it primarily addresses theoretical and simulation-based findings, lacking real-world implementation and validation through experimental case studies.

Golder and Williamson (2022) investigated the incorporation of renewable and clean sources of energy, such as fuel cells, solar photovoltaic panels, and energy storage systems, into EV charging stations, aiming to mitigate their impact on the grid. The study investigated various strategies and forms of EMS implemented in charging stations. The authors analyzed existing research approaches to develop EMS for EV Charging Stations (EVCS), focusing on optimization models, machine learning (ML), and game theory. Furthermore, they expounded on the possibility of future research exploring other alternative approaches, such as Multi-Agent Systems (MAS), Model Predictive Control (MPC), genetic algorithms (GA), and particle swarm optimization (PSO). The study primarily focuses on existing EMS approaches but lacks real-world validation and scalability assessments for large-scale EV charging stations. Additionally, while alternative methods such as Multi-Agent Systems, Model Predictive Control, Genetic Algorithm, and Particle Swarm Optimization are not included, their feasibility and comparative advantages remain unexplored.

In Chen et al. (2023), the authors introduced an energy management strategy for fast-charging stations based on deep reinforcement learning. A mathematical optimization model is formulated to minimize day-to-day electricity purchase costs while managing peak power constraints. The control strategy is developed using the deep deterministic policy gradient algorithm. A case study is performed to validate the effectiveness of the proposed control strategy. The outcomes demonstrate a significant decrease in peak load power, validating the strategy's effectiveness. The computational complexity and scalability of the deep reinforcement learning approach for large-scale fast-charging networks remain unaddressed.

Qian et al. (2023) proposed a mathematical model to characterize the radial distribution network (RDN) load. The EV charging control issue is formulated as a Markov decision process (MDP) to determine an optimal charging control strategy that balances V2G profits, RDN load, and driver anxiety. A federated deep reinforcement learning algorithm is proposed to effectively derive the optimal EV charging control strategy. The obtained results illustrate the efficacy and superiority of the proposed algorithm in terms of the diversity of the charging control strategy, power fluctuations on RDN, convergence efficiency, and generalization capability.

Raja et al. (2023) introduced a collaborative optimal navigation and charge planning (CONCP) framework utilizing multi-agent deep reinforcement learning. The proposed framework computed the optimum route from source to final destination for each autonomous EV planning charge intervals, avoiding obstacles, minimizing traffic congestion, and optimizing energy consumption. Experimental results show that CONCP achieves 27% higher success rates, 31% fewer collisions, and 37% higher rewards per episode than other state-of-the-art algorithms.

Katkar and Goswami (2020) provided a comprehensive review of EMSs applied to Hybrid EVs (HEVs) and Plug-in Hybrid EVs (PHEVs). The study categorized current strategies into two frameworks, rule-based and optimization-based strategies, including applying AI algorithms for real-time optimization. These AI-based EMSs can tackle internal energy management challenges like speed prediction, state-of-charge estimation, and multi-parameter optimization. Although this paper provided a systematic review of various techniques, it does not compare the strengths and weaknesses of each method in detail to provide specific recommendations on the most suitable EMS for different vehicle types and operational scenarios.

Lee et al. (2020b) investigated advanced control strategies focusing on the application of reinforcement learning (RL) to refine internal energy management for HEVs. The study compared RL-based strategies with deterministic dynamic programming (DDP) and stochastic dynamic programming (SDP) across multiple driving cycles to evaluate their impact on fuel efficiency and overall power management. The results demonstrated that RL-based EMS strategies can achieve near-optimal results comparable to SDP and DDP, demonstrating their efficiency for time-variant control problems with complex boundary constraints. Furthermore, the authors examined how value initialization with transfer learning could improve the rate of RL-based controller convergence, thus increasing their applicability for real-time energy management in dynamic driving scenarios. The computational complexity and hardware implementation challenges of RL-based strategies for real-time energy management remain unaddressed.

In a similar context, Han et al. (2021) introduced a multidimensional matrix framework to derive the parameters of an actor-network for a deep deterministic policy gradient (DDPG)-based EMS. A Hardware-in-the-loop (HiL) experiment is performed to verify the real-time feasibility of the proposed strategy. Through HiL experiments, the study validated the real-time feasibility of the proposed strategy for energy management, showing a 13.1% improvement in performance compared to a Double Deep Q-Learning (DDQL)-based strategy. This framework also showed improved robustness in fuel economy with a 3.5% improvement over the DDQL. This strengthened the idea that state of the art deep learning methods could be applied to complicated energy flow environments that involve electric vehicles (EVs).

Additionally, Shin et al. (2019) developed a cooperative control strategy for decentralized EV charging station scheduling. The proposed approach efficiently handles real-time dynamic data to generate scheduling solutions for several charging stations, significantly reducing operating costs. The study shows the benefit of both real-time data processing and decentralized control in EV energy management and demonstrates how internal EMS strategies can be expanded to enhance EV charging efficiency and reduce overall energy costs.

These studies highlighted the growing importance of AI-driven approaches in addressing internal energy management problems in EVs. Nevertheless, most research has focused on hybrid configurations or external energy management strategies, partly due to the challenges of integrating renewable energy sources into the grid and the need to manage charging infrastructure to ramp up EV adoption intentionally. External energy management strategies, such as V2G systems, have garnered attention because they directly address grid stability and peak demand issues, which are critical for supporting large-scale EV deployment. Hybrid configurations have been the focus of research because they offer a transition pathway between ICE cars and full EVs,

providing immediate reductions in emissions while leveraging existing technologies.

However, the analysis of the previously mentioned solutions did not capture the details and challenges of pure EVs, especially regarding their internal energy management system (EMS). Pure EVs only depend on batteries to store and distribute energy. Without hybridization, pure EVs require a sophisticated solution to manage energy utilization in real-time, maximize battery lifespan, and support vehicle performance under various driving conditions and driver demand. This paper identifies those gaps by providing a comprehensive review of AI-based EMS approaches applied to internal energy management in pure EVs. The review will specifically focus on and expand on the various AI approaches relevant to pure EVs, e.g., machine learning, reinforcement learning techniques, and neural networks, and their role in optimizing energy distribution to support battery life and vehicle performance.

3. Research methodology

We perform a systematic literature review (SLR) to explore various AI methodologies applied to EV-EMS. This SLR examines how these techniques enhance energy distribution, improve vehicle performance, and facilitate the integration of renewable energy sources. Originally developed in the medical sciences, SLRs are now widely employed across various disciplines to ensure a comprehensive and unbiased synthesis of existing knowledge. We adhered to the structured guidelines proposed by Kitchenham et al. (2004) for conducting systematic reviews in software engineering and related domains. The primary objective of our SLR is to address the following overarching research question:

How can energy management techniques be integrated with AI? What is the desirable characteristics for energy management?

It is crucial to consider key desirable characteristics such as computational efficiency, real-time adaptability, cost-effectiveness, and robustness to varying driving conditions to evaluate and compare different energy management strategies.

This broad inquiry is divided into the following specific research questions (RQs) to focus the investigation and provide actionable insights:

3.1. Research questions

To provide a comprehensive understanding of AI's role in EV-EMS, we address the following research questions:

RQ1 How can state-of-the-art machine learning models leverage granular vehicle data in EVEMS, ensuring optimal performance and longevity under diverse operating conditions?

This question explores the specific role of advanced AI models in handling EV operations' dynamic and multi-faceted nature. By addressing RQ1, we intend to uncover how granular data (e.g., battery status, driving patterns, energy consumption) can be harnessed to optimize energy usage, improve battery life, and adapt to varying conditions.

RQ2 What are the common taxonomies for energy management in electric vehicles?

With this question, we aim to classify and understand the primary categories of EMSs in EVs, such as rule-based, optimization-based, and AI-driven strategies. This taxonomy helps identify the evolution of EMS approaches and their applications across different scenarios.

RQ3 What are the most commonly and widely used AI applications energy management methods? What are the advantages and disadvantages of each AI method?

This question analyzes popular AI techniques used in EV EMSs, highlighting their strengths and weaknesses. Addressing this will offer insights into the trade-offs involved in selecting a particular method for specific applications.

RQ4 What are the promising research directions for energy management in EVs?

This question aims to identify gaps in the current research landscape and suggest potential areas for future exploration. This includes emerging AI technologies, integration with renewable energy, and enhancing the scalability and adaptability of EMSs.

The research questions are designed to systematically address the challenges and opportunities in using AI for EV energy management. RQ1 focuses on leveraging granular data because effective EMSs rely on accurate and detailed input to make informed decisions. RQ2 is necessary to establish a clear framework for understanding the scope of EMS methodologies, serving as a foundation for the subsequent analysis. RQ3 seeks to evaluate the practical effectiveness of existing AI approaches, aiding researchers and practitioners in selecting suitable methods. Finally, RQ4 ensures that the study not only reflects the field's current state but also guides future research and development efforts, aligning with the evolving needs of EV technology.

By structuring our review around these questions, we aim to provide a comprehensive overview of the role of AI in EV-EMSs and offer actionable insights to researchers, policymakers, and industry professionals.

3.2. Search query formation

To ensure a comprehensive review, the IEEE Xplore digital library is utilized to search for relevant research articles published between 2018 and 2024. Our search focused on journals and conference proceedings that addressed the intersection of AI methodologies and EV energy management.

The search process focused on the topic “Electrical vehicle Energy Management” with the other existing phrases related to the domain of “Artificial intelligence”. We define five sets of keywords presented as follows:

1. Electric vehicle
2. Energy management
3. Charging infrastructure
4. Charging network
5. Artificial intelligence OR machine learning

The search query was refined iteratively to include synonyms and closely related terms, and the IEEE search engine was configured to filter results by title, abstract, and keywords, ensuring a targeted selection process.

3.3. Study selection

The selection process was conducted systematically to identify high-quality papers addressing the above research questions. This process included the following steps:

1. Initial Search and Filtering: We began by executing our defined query on the IEEE Xplore database, which resulted in 1975 papers. These papers were filtered based on relevance, resulting in 1925 unique papers after removing duplicates.
2. Applying Inclusion and Exclusion Criteria: We then applied specific criteria to refine the results further. Papers that did not focus on EV energy management or did not incorporate AI, Machine Learning, or related techniques were excluded. Additionally, non-English papers and articles from low-impact venues were filtered out, reducing the set to 133.

Exclusion criteria. By checking the body of the selected papers, we excluded:

- Articles not related to electric vehicles energy management.
- Articles not covering ML, AI, DL.
- Articles not written in English.
- Articles not published in high-quality conferences (cited less than 20)

Inclusion criteria.

- If multiple versions of an article are available, such as a conference paper and a subsequent journal publication, we prioritize and include the more detailed and comprehensive version, typically the journal version.
3. Manual Review: The remaining articles were manually reviewed by analyzing their titles, abstracts, and main content. This process identified 58 highly relevant papers covering both internal and external EMSs. Since this study focuses on internal EMSs, the selection was further refined to 23 papers.
 4. Snowballing Process: To ensure comprehensive coverage, the reference lists of the selected articles were examined to identify additional relevant studies. Titles, publication venues, and years were assessed to determine suitability for inclusion. The inclusion and exclusion criteria were applied for any potentially relevant articles. This process accounted for limitations in the initial search phase and added three more papers, bringing the final set to 26 papers.

3.4. Search results

The systematic selection process resulted in a final set of 65 papers published between 2018 and 2024, concentrating on AI-based energy management strategies for EVs. Out of these, 26 papers specifically address internal energy management systems for EVs using AI methodologies. These papers are categorized and summarized in [Table 1](#), with particular attention to the research questions identified.

4. Discussion

In this section, the selected papers have been studied based on three main categories, including “Energy Consumption”, “Charging Strategy”, and “Battery Management” to address our research questions:

RQ1: How can state-of-the-art machine learning models leverage granular vehicle data in EVEMS, ensuring optimal performance and longevity under diverse operating conditions? The state-of-the-art machine learning models applied to EV-EMS leverage granular vehicle data to optimize energy consumption, charging strategies, and battery management, enhancing performance and longevity. Techniques like reinforcement learning, deep learning, and transfer learning enable the EMS to adapt dynamically in real-time, optimizing energy use and battery management through predictive maintenance and targeted energy distribution. Optimization algorithms and multi-agent models provide collaborative and scalable solutions that support multi-objective goals and efficient system coordination. These advanced models enable EV-EMSs to balance the immediate demands for optimal vehicle performance, such as acceleration and power delivery, with long-term objectives like preserving battery health and extending its lifespan, ensuring sustainable energy efficiency across diverse driving scenarios.

1. Energy Consumption: Recent research on energy consumption for EVEMS highlights the application of advanced machine learning and optimization methods to enhance energy efficiency and battery life under varying driving conditions. Adaptive optimization techniques, such as particle swarm optimization

Table 1
Journals and conferences selected for the study.

Sources	Acronyms	Number of papers
IEEE Transportation Electrification Conference and Expo	ITECAsia	1
IEEE Vehicle Power and Propulsion Conference	VPPC	3
International Conference on Intelligent Systems and Advanced Computing Sciences	ISACS	1
IEEE Access	–	5
IEEE Journal of Emerging and Selected Topics in Power Electronics	JESTPE	1
IEEE Transactions on Industrial Informatics	TII	2
IEEE Internet of Things Journal	JIoT	2
IEEE Vehicular Technology Conference	VTC	1
IEEE Intelligent Vehicles Symposium	IV	1
IEEE Transactions on Transportation Electrification	TTE	4
IEEE Transactions on Vehicular Technology	–	4
IEEE Transactions on Intelligent Transportation Systems	T-ITS	1

(PSO), focus on reducing computational overhead while improving energy distribution. These methods rely heavily on accurate digital twin models for reliable results. Deep learning and deep reinforcement learning (DRL) offer robust solutions for capturing complex system relationships and enabling real-time adaptability, although their implementation demands substantial computational resources. Reinforcement learning (RL) and multi-agent reinforcement learning (MARL) are well-suited for dynamic and collaborative environments, supporting multi-objective optimization but requiring extensive data and careful parameter tuning. By leveraging high-resolution vehicle telemetry data, these models can improve predictive accuracy and optimize energy usage in real-time while reducing gradual performance degradation over time. Furthermore, combining knowledge of the driving domain with the data-driven models can enhance robustness to (i.e., being robust against) unseen driving conditions and guarantee uniform EMS efficiency over widely varying operations (Ma et al., 2024). Transfer learning (Guo et al., 2020) accelerates model adaptation by reusing knowledge from existing systems, effectively reducing training time but occasionally facing challenges with generalizing across significantly different contexts.

The methodologies reviewed are broadly classified into optimization algorithms (Zhang et al., 2022), deep learning models (Liu et al., 2019; Tang et al., 2021; Sotoudeh and HomChaudhuri, 2023; Wang et al., 2020, 2023; Li et al., 2021), RL (including MARL) (Xiao et al., 2023; Li et al., 2019; Lin et al., 2021; Yang et al., 2023; Hu et al., 2023; Guo et al., 2020; Lee et al., 2021; Xu et al., 2020; Lee et al., 2020a; Liessner et al., 2019), and transfer learning (Xu et al., 2022; Lian et al., 2020). Optimization algorithms like PSO enhance energy efficiency in dynamic scenarios, leveraging their adaptability to evolving conditions. Deep learning models excel in modeling complex system behaviors but are resource-intensive. DRL and MARL enable multi-objective optimization and adaptability, utilizing data from diverse sources to achieve energy-efficient decision-making. Standard RL methods effectively address changing operational demands, while transfer learning facilitates rapid adaptation across HEV types, minimizing training overhead. Together, these methods enable energy-efficient and adaptive EV-EMS solutions, optimizing both performance and longevity in diverse operating conditions.

2. Charging Strategy: AI-based charging strategies leverage dynamic vehicle and environmental data to optimize energy distribution in EV charging networks and stations. In particular, DRL models, such as DDPG and multi-agent DRL approaches, are increasingly used to improve the efficiency and reliability of charging processes. These strategies enable real-time adaptation to fluctuating demands, grid conditions, and vehicle battery states, reducing operational costs, minimizing peak loads, and optimizing renewable energy sources. Federated Reinforcement Learning (FRL) also provides a decentralized and privacy-preserving

solution for managing charging control across multiple EVs and charging stations. The focus on multi-agent systems enables scalable, cooperative charging management for electric vehicle fleets. It enhances load balancing, making it particularly beneficial for addressing grid stability challenges and energy cost reduction in charging stations.

ML techniques, DRL, and multi-agent systems are transforming the management of EV charging strategies by enabling real-time, adaptive energy allocation across diverse scenarios. These models optimize energy distribution by balancing load demands, reducing peak power, and improving efficiency in individual EV charging stations and more extensive distributed networks. For example, methods like DDPG and FRL facilitate cooperative, decentralized energy management, reducing costs and enhancing grid stability. Furthermore, these techniques are scalable, adaptable, and capable of handling dynamic, data-intensive environments, making them ideal for next-generation EV charging solutions in urban and industrial contexts.

3. Battery Management: State-of-the-art machine learning models can leverage granular vehicle data in EV-EMS by employing various techniques that adapt to EVs dynamic and diverse operating conditions. Fuzzy logic and adaptive neuro-fuzzy inference systems (ANFIS) controllers offer interpretable and efficient battery performance management, making them suitable for stable and predictable systems. However, their reliance on predefined rule sets and static models can limit their effectiveness in complex environments with highly variable or unpredictable conditions, such as frequent driving pattern changes, irregular battery usage, or extreme environmental factors. On the other hand, DRL and deep learning techniques, by utilizing vast amounts of data, can optimize battery usage, extend lifespan, and improve efficiency, although they are computationally demanding. Concurrent learning-based methods further enhance hybrid energy storage system performance, reducing energy loss and providing robustness to disturbances. While varying in complexity, these models aim to optimize energy consumption, ensure battery longevity, and adapt to diverse driving conditions using granular data on vehicle performance, battery status, and environmental factors.

Machine learning models, such as fuzzy logic, ANFIS, deep reinforcement learning, and deep learning, provide capable methods for optimizing energy management in EVs by leveraging more detailed information from the vehicle. These methodologies will ensure optimal performance by adapting dynamically to changes and optimizing battery performance and life. The proposed taxonomy ensures clear distinctions between energy consumption, charging strategies, and battery management by minimizing conceptual overlaps. Energy consumption focuses on AI-driven optimization of driving efficiency and power distribution while charging strategies address scheduling, grid interaction, and infrastructure utilization. Battery management

is dedicated to maintaining battery health and longevity, independent of charging logistics or vehicle energy efficiency. This structured framework enhances clarity, enabling a focused analysis of AI-driven solutions within each domain.

While the fuzzy logic model applies to a stable system, approaches like DRL and deep learning will perform better with their learning abilities, though they introduce significant computational demands. These demands necessitate advanced hardware accelerations and algorithmic optimizations to ensure real-time performance. Hardware accelerations primarily include the use of Graphics Processing Units (GPUs) and Tensor Processing Units (TPUs), which efficiently handle the parallel computations required for deep learning models. Additionally, Field Programmable Gate Arrays (FPGAs) and Application-Specific Integrated Circuits (ASICs) offer customized acceleration with lower power consumption, making them suitable for embedded EV applications.

Furthermore, model compression techniques such as quantization, pruning, and knowledge distillation can significantly reduce computational overhead by decreasing model size and inference latency. Hybrid approaches that combine rule-based control with AI-driven adaptations further enhance real-time feasibility by leveraging domain knowledge to simplify complex decision-making processes. By integrating these hardware and software advancements, AI-driven EV energy management systems (EV EMS) can achieve more efficient, responsive, and real-time optimization of energy management strategies.

RQ2: What are the common taxonomies for energy management in electric vehicles? Based on the analysis of various papers on EV-EMS, three primary categories emerge as standard taxonomies: energy management, charging strategy, and battery management. These categories provide a structured framework to understand the different dimensions of energy management in EVs, including optimizing energy distribution, strategies for effective charging, and maintaining battery health and performance.

1. Energy consumption strategies focus on optimizing power distribution across various vehicle components to enhance energy efficiency and overall vehicle performance. This includes methodologies such as rule-based approaches, which rely on predefined rules set by engineers, optimization-based techniques such as dynamic programming and model predictive control, and learning-based methods leveraging machine learning algorithms such as DRL to adapt to dynamic driving conditions. The recent papers focused on energy management in HEVs and EVs could be classified into:

- **DRL and its Variants:** DRL methods, such as multi-agent DRL (MADDPG) and DDPG, aim to improve power coordination in EVs. They have been widely applied in fuel cell HEVs (FCHEVs) and PHEVs (Xiao et al., 2023; Liu et al., 2019; Zhang et al., 2022; Li et al., 2019; Tang et al., 2021; Lin et al., 2021; Yang et al., 2023; Hu et al., 2023). Integrating DRL with transfer learning (TL) addresses the challenge of adapting EMS to diverse driving conditions and vehicle types, enhancing training speed and efficiency (Xu et al., 2022; Lian et al., 2020; Guo et al., 2020).
- **Hierarchical and Model-based Approaches:** Hierarchical frameworks combine high-level and low-level decision-making, employing strategies like eco-driving and deep neural networks (DNN) for real-time optimization (Liu et al., 2019; Wang et al., 2023). Model-based methods like Equivalent Consumption Minimization Strategy (ECMS) and Deep Q-Networks (DQN) leverage stochastic conditions and future driving information to derive near-optimal solutions. In DRL-based EMSs for HEVs, multi-objective optimization is increasingly being adopted, considering not just fuel economy but also factors

like battery health. Research shows that DRL-based EMSs with multi-objective reward functions perform better under high-speed conditions while ensuring better battery longevity and fuel efficiency

- **Hybrid Approaches with Optimization Algorithms:** DRL combined with optimization techniques, such as GA and PSO, enhances real-time performance and adaptability of EMS, validated through hardware-in-the-loop simulations and real-world driving tests (Liu et al., 2019; Zhang et al., 2022; Tang et al., 2021). MARL incorporates game theory to balance multiple objectives like fuel economy and battery degradation by treating power sources as intelligent agents (Yang et al., 2023).

Energy management strategies in EVs encompass various techniques, from DRL and model-based approaches to hybrid methods integrating optimization algorithms. These strategies aim to efficiently allocate power across components to reduce energy consumption and enhance vehicle performance.

2. The charging strategies optimize the charging process, minimize battery degradation, and ensure efficient energy utilization. These strategies include time-based charging schedules and predictive algorithms that incorporate factors such as grid demand and electricity pricing.

- **Time-based and Predictive Approaches:** Basic time-based strategies optimize charging based on user preferences and cost minimization, while more advanced predictive algorithms consider dynamic electricity pricing, grid load, and user driving patterns to recommend optimal charging times. These approaches protect battery health by avoiding overcharging and ensuring the battery remains within safe operating limits (Chen et al., 2023).
- **Smart Charging and Grid Integration:** Smart charging protocols leverage grid integration and time-of-use pricing to optimize when and how the vehicle charges, providing a dynamic response to grid demand and energy pricing (Raja et al., 2023; Qian et al., 2023).
- **AI-Driven Grid Stability in Renewable-Integrated EMS:** The advanced penetration of renewable energy sources (RES) increases volatility in grid stability. To achieve efficient energy management, AI-based methodologies optimize energy management systems (EMS) by adjusting and optimizing charging/discharging schedules for EVs as energy becomes available.
 - **Real-Time Forecasting and Demand-Supply Matching:** Deep Learning models (i.e., LSTM) will predict renewable generation expectations, enabling effective coordination of EV charging systems.
 - **Reinforcement Learning for Dynamic Load Balancing:** Reinforcement Learning (RL)-based controllers actively monitor charging schedules to mitigate or eliminate overloading and overall grid destabilization involving EV charging based on real-time energy supply needs.
 - **V2G Optimization:** AI-based intelligence will optimize EV discharging to the grid while EVs are in a parking mode during peak load periods to reduce dependency on fossil fuel-utilized power generation.
 - **Blockchain and Federated Learning for Decentralized EMS:** Smart contracts using blockchain enable energy trading between EVs and grid in support of dynamic dispatch needs through instantaneous EV charging scheduling while federated learning will optimize grid stability without compromising data privacy principle.

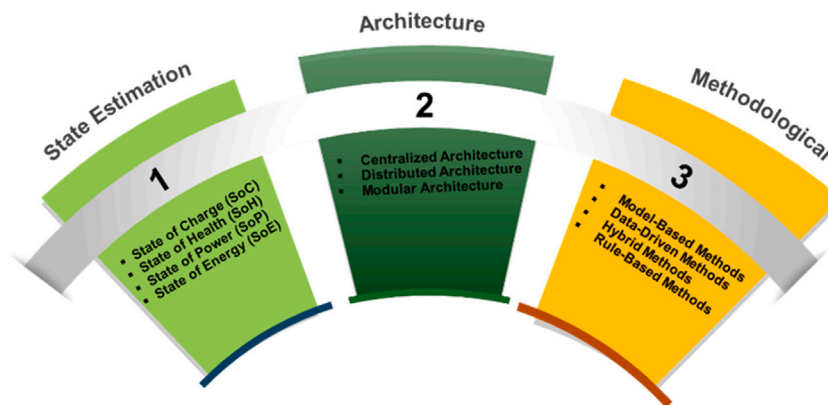

Fig. 3. Battery Management Diagram.

Charging strategies in EVs include time-based and predictive approaches that optimize charging schedules to balance battery health, grid demand, and electricity pricing. Advanced AI-driven techniques integrate with renewable energy sources and smart grids to enhance grid stability and energy efficiency, ensuring a scalable and sustainable EV infrastructure.

3. Battery management deals with maintaining and monitoring a battery's health to maximize its lifespan and ensure safety. Key tasks include real-time monitoring of the SoC and state of health (SoH), balancing cell voltages, and thermal management to prevent overheating. Advanced machine learning models and data analytics are increasingly used to predict battery degradation and optimize charging and discharging cycles. Together, these categories form a comprehensive framework for managing the energy needs of electric vehicles, enhancing efficiency, longevity, and overall performance. Battery management in EVs can be categorized into three primary classes: Learning-based Approaches, Intelligent Control Systems, and Hybrid Storage with Machine Learning Techniques. These categories provide a structured framework for understanding various battery management techniques and their applications (see Fig. 3).

1. Learning-based Approaches: Learning-based techniques, including reinforcement learning and concurrent learning, have gained prominence in battery management. These methods dynamically optimize energy use in hybrid energy storage systems (HESS) that combine batteries with ultra-capacitors. For instance, learning-based strategies can handle external disturbances and uncertainties, improving overall system performance. Mukhcrjee and Sarkar (2023) propose a method that reduces energy loss significantly by optimizing the use of ultra-capacitors without constraining the SoC, making it a robust solution for plug-in hybrid electric vehicles (PHEVs) (Chaoui et al., 2018).
2. Intelligent Control Systems: Intelligent control systems, such as fuzzy logic and ANFIS, are widely used for managing battery energy. These controllers make decisions based on parameters like SoC and driving conditions to enhance efficiency. Suhail et al. (2021) demonstrated how intelligent control systems improve battery performance and fuel efficiency in PHEVs, with ANFIS outperforming traditional fuzzy logic controllers. This highlights the potential of adaptive control techniques in optimizing energy use and extending battery life.
3. Hybrid Storage and ML Techniques: HESS, which combines Li-ion batteries with supercapacitors, is another promising avenue for efficient energy management. Machine learning models are increasingly employed to optimize energy distribution between the battery and supercapacitor, particularly during peak power demands. Alaoui's work (Alaoui, 2019)

shows how machine learning can maximize the efficiency of these hybrid systems, ensuring optimal performance during dynamic driving conditions.

Battery management strategies in EVs focus on optimizing energy storage system performance, lifespan, and safety. Learning-based techniques, such as deep reinforcement learning, enhance efficiency and reduce energy loss. In contrast, advanced control methods like fuzzy logic and adaptive neuro-fuzzy systems support optimal energy allocation and extend battery life. Additionally, integrating lithium-ion batteries with supercapacitors improves the performance of HESS. These advancements collectively enhance the efficiency and reliability of EVs, boosting their market potential.

RQ3: What are the most commonly and widely used AI applications energy management methods? What are the advantages and disadvantages of each AI method? The most used energy management methods in AI applications for EVs and HEVs can be categorized into energy consumption, charging strategy, and battery management.

1. Energy Consumption: This summary draws on insights from recent papers focusing on energy consumption in electric and hybrid vehicles. Various AI methods—including RL, DRL, DL, and TL demonstrate distinct strengths and limitations, making them suitable for different energy management strategies (see Table 2).

- PSO and Adaptive PSO: is widely used in EMS due to its simplicity and adaptability. Specifically, adaptive PSO allows for rapid convergence to optimal solutions, even in dynamic driving environments (Zhang et al., 2022).
- Deep Learning: DL models predict powertrain behavior and optimize energy allocation in complex driving cycles, leveraging large datasets for precise control (Liu et al., 2019; Sotoudeh and Hom-Chaudhuri, 2023; Wang et al., 2023).
- Deep Reinforcement Learning: DRL combines deep neural networks with RL frameworks to provide adaptive and dynamic decision-making in real-time EMS. It optimizes control policies through trial and error in simulated environments, such as with Deep Q-learning or policy gradient methods. In hybrid battery systems for electric vehicles, DRL-based methodologies have shown to be capable of reducing energy loss while also improving electrical and thermal safety levels, while achieving a higher level of efficiency in energy and computation time compared to traditional methods

Challenges in DRL for EMS: DRL is effective, but has a number of practical challenges inhibiting actual implementation:

- High Computational Cost: Training a DRL model necessitates large amounts of computer power and simulation environments.

- Sample Inefficiency: DRL depends on large amounts of training data that continues to make real-world applications problematic.
- Training Instability: Performance is sensitive to hyperparameters, and consequently parameters need to be tuned efficiently.
- Real-Time Feasibility Issues: Inference delays can result in poor responsiveness of EMS applications.

Potential Solutions: Hybrid RL (combining RL with rule-based optimization), Offline RL (training on pre-collected datasets), and Model-Based RL (integrating physics models) can mitigate these challenges.

- Reinforcement Learning: RL and its variants, particularly model-based offline RL, are frequently applied in energy management techniques that improve the energy efficiency of hybrid electric vehicles. These methods alleviate the issues of sample inefficiency and unsafe exploration with the aid of historical datasets, which improve performance in real-time, and/or reduce the simulation-to-real gap. Standard RL approaches like Q-learning and SARSA are widely used in EMS for their adaptability and effectiveness in optimizing fuel and battery management across various driving cycles (Li et al., 2019; Xu et al., 2020; Liessner et al., 2019; Lee et al., 2020a; Yang et al., 2023; Lin et al., 2021; Lee et al., 2021; Guo et al., 2020; Hu et al., 2023).

Explainability Challenge: Although deep learning (DL) and reinforcement learning (RL) techniques have a high accuracy level, these techniques still work as black-box models and lack transparency in the decision-making process.

Proposed XAI Solutions:

- Feature Attribution Methods: Approaches like SHAP (SHapley Additive Explanations) and LIME (Local Interpretable Model-Agnostic Explanations) can be used to explore the effects of input parameters (e.g., battery SoC, driving speed) on the predictions of energy efficiency.
- Surrogate Models: Interpretable models (e.g., decision trees) approximate more complex DL models so humans can interpret outcomes more easily.
- Hybrid AI Approaches: The use of RL with rule-based optimization can ensure decisions are compatible with engineering constraints.

These approaches enhance transparency for AI energy consumption prediction models and help ensure compliance with energy efficiency regulations.

- Multi-Agent Reinforcement Learning: MARL models multiple vehicle components (e.g., engine, battery, ultracapacitors) as separate agents that can cooperate or compete, allowing for multi-objective optimization (Xiao et al., 2023).
- TL for EMS Adaptability: TL enhances AI-based EMS by adapting models across different driving cycles, vehicle types, and operational conditions

Key Applications of TL in EMS:

- Driving Cycle Adaptation: AI models trained for urban traffic can be fine-tuned for highway driving without full retraining.
- Vehicle-to-Vehicle Transfer: TL allows EMS models trained on one EV type (e.g., BEVs) to be adapted for another (e.g., PHEVs).
- Simulation-to-Real Transfer: Pre-trained AI models can be refined with real-world sensor data to enhance deployment reliability.

These applications demonstrate that TL is an indispensable strategy for making AI-driven EMS adaptable and scalable.

Each approach serves specific EMS needs, with RL and DRL providing real-time adaptability, TL improving model flexibility, and optimization algorithms such as PSO offering computational efficiency. This diversity allows EMS designers to choose the most suitable method based on application-specific requirements and available computational resources.

2. Charging Strategy: Based on the analysis of recent papers on charging strategy (Han et al., 2021; Shin et al., 2019; Chen et al., 2023; Qian et al., 2023; Raja et al., 2023), the most commonly used AI methods in energy management for EV charging and energy storage are DRL, MADRL, and FRL (see Table 3).

- Deep Reinforcement Learning: DRL, especially the DDPG algorithm, is widely used for energy management in EV charging stations and hybrid electric vehicles, offering a continuous learning environment for dynamic demands (Han et al., 2021; Chen et al., 2023). However, DRL requires significant computational resources for training and may struggle with convergence in highly complex or uncertain environments.

Limitations of DRL for EV Charging: While DRL can develop adaptive charging schedules and load balance, its real-world deployment faces significant challenges:

- High Computational Cost: DRL models often require extensive training to converge within the training process, sometimes taking weeks to train for large-scale charging networks.
- Sample Inefficiency: To learn an optimal charging policy suffers from sample inefficiency and likely requires millions of interactions, making real-time adaptation to the grid impractical.
- Scalability Issues: the challenge of utilizing DRL approaches will be complicated by high dimensional state–action spaces and multi-agent charging systems.
- Regulatory Challenges: The black-box nature of DRL is a challenge when regulating charging decisions.

Proposed Solutions to DRL Challenges:

- Hierarchical RL: Making a distinction between optimizing the grid demand for long-time periods (macro decisions) versus charging planning (micro decisions) can increase efficiency.
- Hybrid Optimization Models: DRL plus rule-based algorithms provide safety compliance and explainable decision-making.
- Offline RL: If a DRL model can be trained by exposure to historical grid load data before deployment, sample efficiency can be dramatically increased.
- XAI for Regulatory Compliance: Using feature attribution methods (e.g., SHAP/LIME) will allow grid operators to interpret charging policies to validate decisions.

Explainability Challenge: DRL models identify optimal charging rules through trial-and-error processes. However, the solutions of these models are not easily interpretable, making them susceptible to scrutiny by regulatory agencies.

Proposed XAI Solutions:

- Attention Mechanisms: RL models with explainability-enhanced capabilities may include attention layers to highlight prominent factors influencing charging decisions (e.g., energy costs, peak times).
 - Rule-Based Hybrid AI Models: Using RL with explicit constraints on charging regardless of and in addition to safety rules involving batteries permits and promotes the behavior of interpretable and safety-compliant decisions.
 - Multiagent Deep Reinforcement Learning: MADRL enables distributed energy management across multiple EV charging stations and autonomous vehicles, effectively handling decentralized and dynamic environments (Shin et al., 2019; Raja et al., 2023).
- Challenges in MADRL:**

- Communication Overhead: Coordinating multiple agents adds computational complexity.
- Coordination Complexity: Coordinating both EV stations necessitates extensive bandwidth data communications.
- Scalability Concerns: Increasing numbers of EVs may cause MADRL models to not generalize to large-scale charging networks.

Potential Solutions for MADRL Scalability:

- Decentralized Learning: Direct interactions decrease reliance on a central controller, improving real-time feasibility.
 - Graph Neural Networks (GNNs): GNNs will model efficiently shared interdependencies between charging stations.
 - Hierarchical Coordination: Clustering EVs into local groups simplifies multi-agent learning and reduces overhead.
- Federated Reinforcement Learning: FRL merges the advantages of multiagent learning with data sharing and privacy preservation, making it suitable for managing EV charging from disparate grid operators (Qian et al., 2023). FRL poses serious challenges for practical implementations in the real world. The main realistic barriers to FRL implementations are communication latency, data privacy, and scalability.

Challenges in FRL-Based Charging Optimization:

- Communication Latency: FRL requires frequent model updates to occur between the distributed EVs and the aggregators. These updates can exacerbate network congestion issues.
- Data Privacy Risks: Although FRL prevents direct data sharing, an explosive number of model updates can also expose sensitive EV charging patterns.
- Scalability Issues: As the number of participating EVs grows, the cost of model aggregation becomes an issue due to the computational burden it imposes.

Potential Solutions for FRL Challenges:

- Asynchronous Learning: Allow local models to update asynchronously to reduce waiting times.
- Edge Computing: Performing updates at the local level minimizes delays from transmission to the cloud.
- Hierarchical FRL: Grouping EVs into clusters based on region makes federated updates more efficient.

Proposed XAI Solutions:

- Differential Privacy with XAI: Adding explainability layers to encrypted model updates can ensure model updates have interpretability while maintaining privacy protection.
- Hierarchical Interpretability Models: Explainability techniques can be used to analyze FRL-driven decisions through a regional interpretability approach at the microgrid and urban levels.

Applying these explanatory techniques not only promotes regulatory acceptance of AI, but also presents value to practical implementation in the real world.

Charging strategies for electric vehicles increasingly leverage multiple AI methodologies to enhance energy management, including DRL, MADRL, FRL, machine learning, fuzzy logic, and optimization algorithms. Each method offers unique strengths and faces specific challenges, making them suited to different aspects of EV energy management. In conclusion, each of these methodologies contributes uniquely to optimizing EV charging strategies.

3. Battery Management: AI-based methods are crucial for battery management in electric and hybrid vehicles, each with specific advantages and challenges. Based on the four papers, AI is increasingly adopted in electric vehicle energy management to address the complexity and variability of energy demands. The most commonly used AI methods include Fuzzy Logic Control (FLC), ANFIS, DRL, and DL. Fuzzy Logic and ANFIS provide straightforward, interpretable control for stable hybrid systems, effectively handling uncertainty with minimal computational demand. In contrast, deep reinforcement learning and deep concurrent learning offer more adaptable, efficient energy management and dynamically optimized battery use for immediate needs and long-term health, but at the cost of high computational requirements. Deep Learning also supports complex hybrid systems, optimizing energy flows across multiple sources, but demands extensive data and computational resources to perform optimally.

- Deep Reinforcement Learning: DRL leverages complex policy learning for energy management, allocating resources optimally under diverse operational conditions. It is beneficial for managing systems with multiple energy storage devices, such as batteries with different charging behaviors (Chaoui et al., 2018).

Limitations of DRL in Battery Management: Despite its advantages, DRL has several difficulties associated with using it for battery control:

- Battery Degradation Risks: The control policy based on DRL may suboptimally prioritize short-term energy efficiency over long-term battery degradation, often increasing battery aging and thermal instability.
- High Computational Cost: DRL models require substantial computational resources to discover optimal battery management policies, but they are limited to application in real-time.
- Sample Inefficiency: Collecting large amounts of data needed to train the DRL for battery state of charge/state of health (SoC/SOH) estimates is expensive and time-consuming.
- Lack of Explainability: Due to its black-box nature, DRL raises feasibility questions around battery longevity, thermal safety, and possible regulatory approval.

Proposed Solutions to DRL Challenges:

- Physics-Informed DRL: Incorporating battery degradation models and electrochemical constraints into DRL training ensures battery longevity is preserved.
- Hybrid AI Approaches: Using DRL in conjunction with rule-based controllers provides battery management, which is not only safe but interpretable.
- Offline RL for Battery Health Monitoring: Pretraining DRL on historical battery degradation data reduces the need for excessive real-time exploration.
- Transfer Learning for Battery SoH Estimation: TL DRL models trained on particular battery chemistries, such as lithium-ion, can be transferred to explore and estimate battery SoH in future battery types (e.g., solid-state batteries).

Explainability Challenge: DRL-based battery management policies lack interpretability, which raises battery degradation and thermal stability concerns, particularly when the battery is under load.

Proposed XAI Solutions:

- Physics-Informed Neural Networks (PINNs): These artificial intelligence approaches embed battery physics equations into deep learning models to account for electrochemical boundaries while making decisions.
- Bayesian Deep Learning (BDL): Provides uncertainty estimation for battery SoC (state of charge) estimates, which is an important resource for understanding how confident the AI is in its decision.

- **Deep Concurrent Learning (DCL):** This advanced technique uses a concurrent learning framework to manage HESS in PHEVs. DCL minimizes energy loss and handles external disturbances by introducing a reward structure that optimizes the control policy (Mukhrjee and Sarkar, 2023).
- **Deep Learning:** DL models are used to manage energy demands between batteries and supercapacitors in hybrid systems, focusing on maximizing the efficiency of these storage devices (Alaoui, 2019).

Challenges in DL-Based Battery Management:

- **Data Requirements:** Training correct DL-based models for battery health monitoring requires vast labeled datasets that are not easy to obtain.
- **Generalization Issues:** DL models trained in specific battery types may not generalize well to newer battery chemistries.

Proposed Solutions for DL Battery Management:

- **Transfer Learning for SoH Adaptation:** TL is a tool that allows battery models to be pre-trained on different battery chemistries and fine-tuned for different battery chemistries.
- **Hybrid DL Models:** Combining data-driven models with physics-based constraints helps address generalization issues.
- **FLC and ANFIS:** Fuzzy logic is particularly effective in dealing with the uncertainty and imprecision inherent in battery data, such as fluctuations in SoC or temperature. FLC and ANFIS combine human-like reasoning with mathematical control to handle energy distribution in HEVs. These systems use battery state of charge and engine speed to manage the torque and energy requirements (Suhail et al., 2021). FLCs are relatively simpler to design and implement than AI techniques. Fuzzy logic systems are robust against variations in battery behavior and external conditions, making them reliable for real-time applications.

Proposed XAI Solutions:

- **Fuzzy Rule-Based AI Enhancements:** Combining Fuzzy Logic with reinforcement learning helps improve explainability while maintaining adaptability

Fuzzy Logic and ANFIS provide straightforward, interpretable control suited for stable hybrid systems, while Deep Reinforcement Learning and Deep Concurrent Learning offer more adaptable, efficient energy management at the expense of higher computational demands. Deep Learning is effective in hybrid setups with multiple energy sources but requires extensive data and computational resources to achieve optimal results. Each method has strengths in different operational contexts, making the choice of AI technique dependent on the specific energy management needs and available computational resources.

To provide a structured and quantitative comparison, Table 4 evaluates AI-based energy management strategies concerning key performance indicators frequently reported in EVENS research. These indicators help assess the performance trade-offs between computational efficiency, energy savings, battery life, and real-time decision-making capability.

- **Computational Complexity:** Refers to the process demands the algorithm requires to run, a contributing factor in determining the feasibility of real-time applications.
- **Training Time:** The duration needed for the AI model to learn the strategies for optimal energy management.
- **Convergence Rate:** The number of iterations for the AI model to achieve stable performance.
- **Gain in Energy Efficiency (%):** The improvement in EV energy consumption is attributable to the AI strategy.
- **Gain in Battery Life (%):** The estimated battery life extension due to the optimized charge/discharge cycles.

- **Computational Cost (ms per decision):** The processing time required for the AI system to generate a decision for real-time applications.
- **Real-Time Adaptability (ms response time):** The ability of the AI method to adapt to capabilities for both changing driving conditions and fluctuation on the grid.
- **Interpretability (XAI):** The extent to which the AI model's decisions can be explained and understood.

Role of Transfer Learning in EV Energy Management Transfer Learning (TL) plays an integral role in helping to develop smart and adaptive EV energy management systems (EV EMS). It facilitates the transfer of existing, pre-trained models to new driving conditions and operational circumstances with minimal re-training. TL improves model generalization, can ease issues with scarce data, and supports AI-driven optimization techniques such as deep reinforcement learning (DRL) to converge rapidly. Moreover, TL also reduces computational overhead while increasing the efficiency and/or accuracy of energy management decisions. TL is particularly advantageous in the following EV EMS methods:

- Fostering Domain Adaptation Between Driving Cycles:** AI models trained on a specific driving cycle (e.g. urban driving with frequent stops) may not generalize to another driving scenario (e.g., highway driving with less frequent stops).
TL Solution: Instead of training a new model from scratch on the second driving scenario, using TL, one can instead fine-tune the existing model with a limited set of driving data for the second cycle. This allows the model to be adapted and the energy efficiency predictions improved without having to re-train the model extensively (Lian et al., 2020; Xu et al., 2022).
- Transfer from Simulation to Real World:** Due to constraints on safety and cost, AI models to evaluate EV energy mgmt strategies are often developed and evaluated in simulator environments, however, AI models or other models trained within simulations do not perform as well in real-world driving because real-world driving contains uncertainties that are not modeled and addressed in the simulation environment.
TL Solution: Pretraining an AI model within a high-fidelity EV simulator (e.g., CARLA, SUMO) and fine-tuning this model with real-world data from a limited number of sensors will allow for better adaptation while avoiding the costs and time associated with collecting additional data (Wang et al., 2020; Li et al., 2021).
- Adapting AI Models to New Battery Chemistries:** Whenever battery materials and chemistries change (e.g., lithium-ion vs. solid state), the charging dynamics and capacity fade behavior will change, necessitating new control strategies.
TL Solution: Rather than fully retraining the AI model for the battery type, you can similarly transfer the model's features and fine-tune it with limited experimental data on the new battery type, greatly reducing training costs (Yang et al., 2023).
- Vehicle-to-Vehicle (V2V) Knowledge Transfer:** BEVs have a different energy management strategy than PHEVs because they require different powertrain configurations (and electric range).
TL Solution: Even if an AI model would require retraining for the type of EV, it is still not equivalent to retraining an AI model for another vehicle. In this case, transferring knowledge from the BEV will allow the model to adapt to the PHEV more efficiently in real-world deployment (see Table 5).

RQ4: What are the promising research directions for energy management in EVs? Promising research directions for energy management in electric vehicles (EVs) can be categorized into three

Table 2
Energy consumption methods classifications.

Methodology	Advantages	Disadvantages
Optimization algorithm (Zhang et al., 2022)	<ul style="list-style-type: none"> - Adaptive optimization specific to dynamic driving environments. - Improves energy efficiency and reduces computational time through adaptive PSO. 	<ul style="list-style-type: none"> - Limited by the effectiveness of the particle swarm model in complex, unpredictable environments. - Relies on adequate digital twin fidelity and calibration for effective implementation.
Deep learning (Liu et al., 2019; Sotoudeh and HomChaudhuri, 2023; Wang et al., 2023)	<ul style="list-style-type: none"> - Models complex relationships effectively - High accuracy in real-time applications - Scales with large datasets 	<ul style="list-style-type: none"> - High computational needs - Requires long training time
Deep Reinforcement Learning (DRL) (Wang et al., 2020; Tang et al., 2021; Li et al., 2021)	<ul style="list-style-type: none"> - Allows learning from visual input (e.g., camera data) and complex environments. - Improves fuel economy and emission management with deep neural network integration. - Distributed training enables efficient processing in complex scenarios. 	<ul style="list-style-type: none"> - Heavy computational load due to deep neural networks. - It may be challenging to optimize for real-time applications due to large data input.
Reinforcement learning (Li et al., 2019; Xu et al., 2020; Liessner et al., 2019; Lee et al., 2020a; Yang et al., 2023; Lin et al., 2021; Lee et al., 2021; Guo et al., 2020; Hu et al., 2023)	<ul style="list-style-type: none"> - Adaptive learning in complex, changing environments. - Improves energy management and fuel economy. - Handles uncertain environments effectively. - Supports multiple-objective optimizations in real-time. 	<ul style="list-style-type: none"> - High computational demands and training may require extensive data. - Training can be complex and time-intensive - Stability issues in extended scenarios require careful tuning. - Performance is highly dependent on tuning learning rates and reward functions.
Multi-Agent reinforcement learning (Xiao et al., 2023)	<ul style="list-style-type: none"> - Supports collaborative and scalable solutions - Optimizes multi-agent interactions - Increases system efficiency 	<ul style="list-style-type: none"> - Complex implementation - High computational and coordination requirements
Auxiliary AI techniques: Transfer learning (Lian et al., 2020; Xu et al., 2022)	<ul style="list-style-type: none"> - Reduces the need for retraining - Speeds up convergence in new environments - Transfers knowledge effectively - Enables reusability of knowledge across different HEV types, reducing training time - Facilitates efficient development and adaptation for different vehicle configurations 	<ul style="list-style-type: none"> - Adaptation challenges if tasks differ significantly - May not generalize perfectly to new or highly distinct models - Performance depends on the quality and adaptability of pre-trained models

Table 3
Charging strategy methods classifications.

Methodology	Advantages	Disadvantages
Deep Reinforcement Learning (DRL) (Han et al., 2021; Chen et al., 2023)	<ul style="list-style-type: none"> - Real-time adaptability for dynamic energy demands. - Improves fuel economy and reduces peak loads. - Suitable for handling fluctuating load characteristics in EV charging. 	<p>Computational overhead: Requires extensive training resources. <i>Mitigation:</i> Efficient model compression and distributed training. Limited generalization: Performance depends on SOC training. <i>Mitigation:</i> Transfer learning techniques for adaptation.</p>
Multi-agent Deep Reinforcement Learning (MADRL) (Shin et al., 2019; Raja et al., 2023)	<ul style="list-style-type: none"> - Effective in decentralized, distributed EV charging management. - Reduces operational costs and enhances energy efficiency. - High success rate in complex environments for autonomous navigation. 	<p>High coordination complexity: Synchronizing multiple agents requires large-scale computations. <i>Mitigation:</i> Asynchronous updates and reward shaping. Scalability issues: Managing many EVs can be inefficient. <i>Mitigation:</i> Hierarchical multi-agent coordination frameworks.</p>
Federated Deep Reinforcement Learning (FLR) (Qian et al., 2023)	<ul style="list-style-type: none"> - Balances V2G/G2V modes while maintaining driver privacy. - Reduces power fluctuations and optimizes distribution network load. - High generalization ability and convergence efficiency. 	<p>Communication latency: Model synchronization delays affect decisions. <i>Mitigation:</i> Edge computing and adaptive update frequency. Data privacy risks: Model updates may reveal user behavior. <i>Mitigation:</i> Differential privacy and homomorphic encryption. Scalability concerns: Large-scale participation increases computation. <i>Mitigation:</i> Hierarchical FRL and blockchain-based aggregation.</p>

main areas: energy consumption, charging strategies, and battery management.

1. Energy Consumption: In the area of energy consumption, DRL and its various extensions, such as MADDPG and deep Q-networks (DQNs), have demonstrated substantial potential in optimizing

EMS by coordinating power output and reducing energy consumption. Developing model-based offline reinforcement learning to improve sample efficiency and safety are promising research directions for energy management in EVs, as well as data-driven dynamic models to close the simulation to reality gap. These approaches will aim to improve the adaptability and real-time

Table 4
Quantitative comparison of AI-Based energy management methods for EVs.

Metric	Reinforcement learning	Deep learning (CNN/RNN/DNN)	Transfer learning	Fuzzy Logic & ANFIS
Best use case	Real-time energy optimization	Energy prediction	Model adaptation across EVs	Rule-based energy control
AI architecture	Deep Q-Networks (DQN), PPO, DDPG	CNN (image-based), RNN (time-series), DNN (multi-variable)	Fine-tuned pre-trained models	Expert-defined fuzzy rules
Computational complexity	High ($O(n^2)$ - $O(n^3)$)	Medium ($O(n \log n)$)	Low ($O(n)$)	Very Low ($O(1)$)
Training time	Long (10+ hours)	Medium (5–10 h)	Short (2–5 h)	Instant (<1 h)
Convergence rate	Slow (1000+ episodes)	Moderate (100–500 iterations)	Fast (50–200 iterations)	Very Fast (few iterations)
Energy efficiency gain (%)	Moderate (5%–15%)	High (15%–30%)	High (20%–35%)	Low (5%–10%)
Battery life improvement (%)	Moderate (10%–20%)	High (20%–40%)	High (30%–50%)	Low (5%–15%)
Computational cost (ms per decision)	High (100–500 ms)	Medium (50–200 ms)	Low (10–50 ms)	Very Low (<10 ms)
Real-Time adaptability (Response time)	High (<500 ms)	Medium (<1 s)	High (<500 ms)	Very High (<100 ms)
Interpretability (XAI)	Low (Requires SHAP/LIME)	Low (Requires surrogate models)	Moderate (Transferable weights)	High (Inherently transparent)

Table 5
Application Scenarios for Transfer Learning in EV Energy Management.

Application	Role of transfer learning
Driving cycle adaptation	Transfers knowledge from one driving scenario (e.g., urban) to another (e.g., highway) to improve adaptability.
Simulation-to-Real transfer	Fine-tunes AI models trained in simulators for real-world deployment, reducing the need for costly real-world data collection.
Battery chemistry adaptation	Adapts AI models trained on one battery type (e.g., lithium-ion) to another (e.g., solid-state) without full retraining.
Vehicle-to-Vehicle knowledge transfer	Transfer control strategies between different EV models (e.g., BEV vs. PHEV) to enhance cross-platform efficiency.

optimization of energy management systems. Combining DRL with TL is another promising avenue, enabling quicker adaptation and reduced training times by transferring knowledge from one driving domain to another, thus enhancing EMS's efficiency and real-time applicability (Ma et al., 2024; Alaoui, 2019; Chaoui et al., 2018).

Eco-driving strategies that incorporate hierarchical control frameworks are also gaining traction. These frameworks optimize driving cycles and powertrain energy management, leveraging long-term and short-term decision-making for improved computational efficiency and fuel economy. Hybrid approaches integrating deep learning and genetic algorithms further enhance EMS by optimizing power splits between batteries and internal combustion engines, leading to better fuel economy and real-time adaptability. Digital twin (DT) technology, combined with adaptive PSO, offers a robust EMS optimization platform, significantly improving fuel economy and computational efficiency through virtual simulations and real-world validations (see Table 6).

Incorporating computer vision with DRL is another innovative direction, where visual inputs from onboard cameras are used to optimize control policies, improving fuel economy by leveraging real-time visual information. Multiobjective optimization using multiagent reinforcement learning (MARL) addresses various EMS objectives, such as fuel economy and battery SoC maintenance, ensuring a balanced approach to energy management. In conjunction with DRL, Bayesian optimization further refines EMS by optimizing energy management and powertrain configurations, leading to significant reductions in fuel consumption.

Moreover, supplementary learning controllers (SLC) based on DRL enhance existing rule-based EMS, reducing uncertainty and improving convergence speed, thus facilitating the transition from simulation to real-world applications. Adaptive and real-time EMS strategies, incorporating improved reinforcement learning algorithms and hierarchical frameworks, are also crucial for ensuring the adaptability and efficiency of EVs in diverse driving conditions and vehicle types. These advancements collectively point towards a future where AI-driven, adaptive, and highly efficient energy management systems become integral to the operation of electric vehicles.

2. **Charging Strategy:** Promising research directions for energy management in EVs include advancements in battery technology, such as solid-state batteries, which promise higher energy densities, improved safety, and longer lifespans. Enhanced battery management systems (BMS) that utilize machine learning and predictive algorithms can better monitor and adapt to usage patterns, extending battery life and reliability. Additionally, exploring efficient thermal management techniques, such as leveraging real-time data from onboard sensors to dynamically control cooling systems (e.g., reducing heat during high-demand charging), can prevent overheating and improve overall efficiency. For instance, multi-state energy management strategies using DRL, as proposed for hybrid electric-tracked vehicles (HETVs), have improved fuel economy by 13.1% through dynamic demand modeling and robust optimization (Han et al., 2021). Integrating renewable energy sources, such as solar panels, into EVs for auxiliary power is another promising avenue, as demonstrated by MADRL for distributed EV charging stations equipped with solar photovoltaic systems and energy storage systems. This approach reduces operation costs by dynamically scheduling EV charging across multiple stations while adapting to varying data in real-time (Shin et al., 2019). Research into V2G and G2V technologies is also vital. For instance, FRL has been shown to balance V2G profits, mitigate power fluctuations in RDN, and respect driver privacy through decentralized learning frameworks (Chen et al., 2023). Innovative charging infrastructure developments, such as the use of DRL-based control strategies, have been shown to significantly reduce peak load power at EV fast-charging stations, addressing high peak demands and fluctuations (Qian et al., 2023). Additionally, advancements like the CONCP framework for autonomous EVs, powered by MADRL, enhance charging efficiency by scheduling optimal charging stops while improving traffic flow and reducing congestion (Raja et al., 2023). Furthermore, investigating lightweight materials and aerodynamic designs can reduce energy consumption and increase vehicle range. Collectively, these research directions aim to improve electric vehicles' efficiency, sustainability, and user experience.

Table 6
Battery management methods classifications.

Methodology	Advantages	Disadvantages
Fuzzy Logic and ANFIS Control (Suhail et al., 2021)	<ul style="list-style-type: none"> - Simple and interpretable control techniques. - Improves battery performance and efficiency. - Suitable for energy management of PHEVs. 	<ul style="list-style-type: none"> - May achieve a different level of precision than other methods like machine learning, which can limit their effectiveness in some scenarios. - Often requires manual tuning of membership functions and rules, which can be labor-intensive and may only sometimes yield optimal results. - May need help with scalability when applied to large or complex systems.
Deep Reinforcement Learning (DRL) (Chaoui et al., 2018; Ma et al., 2024)	<ul style="list-style-type: none"> - Learns optimal energy management policies automatically. - Improves battery lifespan by balancing SoC across multiple batteries. - Optimizes battery usage over the long term, balancing immediate energy needs with future battery health and longevity. - Suitable for complex energy management in electric vehicles. 	<ul style="list-style-type: none"> - Requires significant computational resources and training time. - Complexity increases with the number of batteries and operating conditions. - Face challenges in balancing exploration (trying new actions) with exploitation (using known actions that work well), which can affect performance.
Deep Concurrent Learning (DCL) (Mukherjee and Sarkar, 2023)	<ul style="list-style-type: none"> - Reduces energy loss in HESS. - Handles external disturbances and modeling uncertainties effectively. - Efficient energy management using continuous-time problem formulation. 	<ul style="list-style-type: none"> - Complexity increases with multiple energy sources and system dynamics. - High computational overhead during the learning phase.
Deep learning (Alaoui, 2019)	<ul style="list-style-type: none"> - Maximizes energy efficiency in HESS. - Combines batteries and supercapacitors for better performance. - Suitable for hybrid vehicle energy management. 	<ul style="list-style-type: none"> - Requires a large amount of data for training. - Computationally intensive and may require significant tuning.

3. Battery Management: Battery management in electric vehicles (EVs) is a rapidly evolving field with several promising research directions to improve efficiency, longevity, safety, and overall performance. They enhance AI algorithms for more precise SoC and SoH estimation, predictive maintenance, and real-time battery performance optimization. Also, developing digital twin models of batteries that simulate their physical and chemical processes in real-time allows for more accurate monitoring and predictive analysis. Moreover, new technologies can significantly reduce charging times without compromising battery health or safety. Research in these areas will help address the current challenges in EV battery management, paving the way for more advanced, efficient, and sustainable electric vehicles.

Addressing the Main Research Question: How can energy management techniques be integrated with AI? What is the desirable characteristics for energy management?

Integrating energy management with AI methodologies in EVs must address computational efficiency, adaptability to real-time conditions, and resilience to data loss or system failures. These AI techniques, which include deep reinforcement learning and transfer learning, can also be the basis for pathways to optimize energy flow in an adaptive and predictive manner, which is essential for managing complex energy distribution and varying demands. One of the primary challenges lies in generalizing AI models, as simulations often fail to capture real-world variations in driving behavior, environmental conditions, and battery degradation. Additionally, computational constraints and safety concerns make direct deployment of complex AI models difficult, necessitating robust adaptation strategies.

To bridge this gap, digital twins have emerged as a promising solution, enabling real-time validation by continuously synchronizing a virtual EV model with real-world data. Furthermore, transfer learning and domain adaptation techniques allow AI models trained in simulations to be fine-tuned using limited real-world datasets, improving their applicability. Hybrid control architectures, where AI-driven energy management is supplemented with traditional rule-based or optimization-based controllers, can enhance robustness and reliability.

For example, fuzzy logic and neural networks can monitor operating conditions and real-time battery and power distribution, effectively and efficiently utilizing power resources while responding to dynamic vehicle performance data. Hardware-in-the-loop (HiL) testing further aids in validating AI models by integrating them with actual EV components before full-scale deployment. The preferred combination of characteristics for AI-related energy management tools in EVs includes cost-effectiveness for model deployment, scalable algorithms for handling large data volumes, resilience to changing operational conditions (e.g., unpredictable driving), and reliability to meet electricity grid demands and variable driving conditions.

Thus, by integrating these strategies, AI-based EV energy management systems can effectively transition from simulation to practical implementation, ensuring efficiency, reliability, and real-time adaptability. These AI-driven energy management strategies not only enable efficient EV operation but also contribute to longer battery longevity and a more sustainable future for mobility and autonomous transportation.

5. Conclusion

This paper discussed the current landscape of AI applications in EVEMS, highlighting the potential of DL, RL, fuzzy logic, and optimization algorithms to transform energy management. AI-driven models allow for efficient and real-time energy distribution, extended battery life, and adaptive vehicle performance management, which are critical to addressing the challenges of dynamic driving conditions and energy demands. The findings emphasize that while DL and RL offer high adaptability and predictive power, simpler models such as fuzzy logic excel in specific stable environments with fewer computational demands. As electric vehicle technology evolves, the integration of AI in energy management will be essential to achieve higher efficiency, greater sustainability, and widespread adoption. This paper encourages further exploration of scalable and adaptable AI approaches that support the diverse needs of the electric vehicle industry, ultimately contributing to a more sustainable transportation future.

In conclusion, this review paper serves as a valuable resource for researchers, practitioners, and policymakers by contributing to ongoing efforts to create more efficient and intelligent energy management solutions, paving the way for the broader adoption of EVs in the global market.

CRedit authorship contribution statement

Azadeh Kermansaravi: Writing – original draft, Methodology. **Shady S. Refaat:** Writing – review & editing, Validation, Formal analysis. **Mohamed Trabelsi:** Writing – review & editing, Project administration, Formal analysis. **Hani Vahedi:** Writing – review & editing, Supervision, Funding acquisition.

Declaration of competing interest

The authors declare that they have no known competing financial interests or personal relationships that could have appeared to influence the work reported in this paper.

Acknowledgments

The project was funded by Kuwait Foundation for the Advancement of Sciences (KFAS) under project code: CN23-13EE-1882.

Data availability

No data was used for the research described in the article.

References

- Abdullah, Heba M., Gastli, Adel, Ben-Brahim, Lazhar, 2021. Reinforcement learning based EV charging management systems—a review. *IEEE Access* 9, 41506–41531.
- Alaoui, Chakib, 2019. Hybrid vehicle energy management using deep learning. In: 2019 International Conference on Intelligent Systems and Advanced Computing Sciences. ISACS, IEEE, pp. 1–5.
- Chaoui, Hicham, Gualous, Hamid, Boulon, Loic, Kelouani, Souso, 2018. Deep reinforcement learning energy management system for multiple battery based electric vehicles. In: 2018 IEEE Vehicle Power and Propulsion Conference. VPPC, IEEE, pp. 1–6.
- Chen, Shihao, Yin, Pengcheng, Bao, Yan, Wang, Zhihao, Shi, Jinkai, 2023. Deep reinforcement learning method for energy management in fast charging station. In: 2023 IEEE Transportation Electrification Conference and Expo, Asia-Pacific (ITEC Asia-Pacific). IEEE, pp. 1–5.
- Golder, Anindita, Williamson, Sheldon S., 2022. Energy management systems for electric vehicle charging stations: A review. In: IECON 2022–48th Annual Conference of the IEEE Industrial Electronics Society. IEEE, pp. 1–6.
- Guo, Xiaowei, Liu, Teng, Tang, Bangbei, Tang, Xiaolin, Zhang, Jinwei, Tan, Wenhao, Jin, Shufeng, 2020. Transfer deep reinforcement learning-enabled energy management strategy for hybrid tracked vehicle. *IEEE Access* 8, 165837–165848.
- Han, Ruoyan, Lian, Renzong, He, Hongwen, Han, Xuefeng, 2021. Continuous reinforcement learning-based energy management strategy for hybrid electric-tracked vehicles. *IEEE J. Emerg. Sel. Top. Power Electron.* 11 (1), 19–31.
- Hu, Bo, Li, Jiayi, 2021. A deployment-efficient energy management strategy for connected hybrid electric vehicle based on offline reinforcement learning. *IEEE Trans. Ind. Electron.* 69 (9), 9644–9654.
- Hu, Bo, Xiao, Yang, Zhang, Sunan, Liu, Bocheng, 2022. A data-driven solution for energy management strategy of hybrid electric vehicles based on uncertainty-aware model-based offline reinforcement learning. *IEEE Trans. Ind. Inform.* 19 (6), 7709–7719.
- Hu, Yue, Xu, Hui, Jiang, Zhonglin, Zheng, Xinyu, Zhang, Jianfeng, Fan, Wenhui, Deng, Kun, Xu, Kun, 2023. Supplementary learning control for energy management strategy of hybrid electric vehicles at scale. *IEEE Trans. Veh. Technol.*
- Katkar, Vaishali A., Goswami, Prerna, 2020. Review on energy management systems for hybrid e vehicles. In: 2020 International Conference on Power, Energy, Control and Transmission Systems. ICPECTS, IEEE, pp. 1–6.
- Kitchenham, Barbara A., Dyba, Tore, Jorgensen, Magne, 2004. Evidence based software engineering. In: Proceedings of the 26th International Conference on Software Engineering. IEEE Computer Society, pp. 273–281.
- Lee, Woong, Jeoung, Haeseong, Park, Dohyun, Kim, Tacksu, Lee, Heeyun, Kim, Namwook, 2021. A real-time intelligent energy management strategy for hybrid electric vehicles using reinforcement learning. *IEEE Access* 9, 72759–72768.
- Lee, Heeyun, Kang, Changbeom, Park, Yeong-Il, Kim, Namwook, Cha, Suk Won, 2020a. Online data-driven energy management of a hybrid electric vehicle using model-based Q-learning. *IEEE Access* 8, 84444–84454.
- Lee, Heeyun, Song, Changhee, Kim, Namwook, Cha, Suk Won, 2020b. Comparative analysis of energy management strategies for HEV: Dynamic programming and reinforcement learning. *IEEE Access* 8, 67112–67123.
- Li, Weihai, Cui, Han, Nemeth, Thomas, Jansen, Jonathan, Uenluebayir, Cem, Wei, Zhongbao, Zhang, Lei, Wang, Zhenpo, Ruan, Jiageng, Dai, Haifeng, et al., 2021. Deep reinforcement learning-based energy management of hybrid battery systems in electric vehicles. *J. Energy Storage* 36, 102355.
- Li, Yuecheng, He, Hongwen, Peng, Jiankun, Wang, Hong, 2019. Deep reinforcement learning-based energy management for a series hybrid electric vehicle enabled by history cumulative trip information. *IEEE Trans. Veh. Technol.* 68 (8), 7416–7430.
- Lian, Renzong, Tan, Huachun, Peng, Jiankun, Li, Qin, Wu, Yuankai, 2020. Cross-type transfer for deep reinforcement learning based hybrid electric vehicle energy management. *IEEE Trans. Veh. Technol.* 69 (8), 8367–8380.
- Liessner, Roman, Lorenz, Alexander, Schmitt, Jakob, Dietermann, Ansgar M, Baker, Bernard, 2019. Simultaneous electric powertrain hardware and energy management optimization of a hybrid electric vehicle using deep reinforcement learning and Bayesian optimization. In: 2019 IEEE Vehicle Power and Propulsion Conference. VPPC, IEEE, pp. 1–6.
- Lin, Xinyou, Zhou, Kuncheng, Mo, Liping, Li, Hailin, 2021. Intelligent energy management strategy based on an improved reinforcement learning algorithm with exploration factor for a plug-in PHEV. *IEEE Trans. Intell. Transp. Syst.* 23 (7), 8725–8735.
- Liu, Teng, Tang, Xiaolin, Wang, Hong, Yu, Huilong, Hu, Xiaosong, 2019. Adaptive hierarchical energy management design for a plug-in hybrid electric vehicle. *IEEE Trans. Veh. Technol.* 68 (12), 11513–11522.
- Ma, Zheng, Luan, YiXuan, Zhang, FengQi, Xie, ShaoBo, Coskun, Serdar, 2024. A data-driven energy management strategy for plug-in hybrid electric buses considering vehicle mass uncertainty. *J. Energy Storage* 77, 109963.
- Mastoi, Muhammad Shahid, Zhuang, Shenxian, Munir, Hafiz Mudassir, Haris, Malik, Hassan, Mannan, Usman, Muhammad, Bukhari, Syed Sabir Hussain, Ro, Jong-Suk, 2022. An in-depth analysis of electric vehicle charging station infrastructure, policy implications, and future trends. *Energy Rep.* 8, 11504–11529.
- Mukhrjee, Nilanjan, Sarkar, Sudeshna, 2023. A deep concurrent learning-based robust and optimal energy management strategy for hybrid energy storage systems in plug-in hybrid electric vehicles. In: 2023 IEEE Vehicle Power and Propulsion Conference. VPPC, IEEE, pp. 01–08.
- Qian, Junkai, Jiang, Yuning, Liu, Xin, Wang, Qiong, Wang, Ting, Shi, Yuanming, Chen, Wei, 2023. Federated reinforcement learning for electric vehicles charging control on distribution networks. *IEEE Internet Things J.*
- Raja, Gunasekaran, Saravanan, Gayathri, Prathiba, Sahaya Beni, Akhtar, Zahid, Khowaja, Sunder Ali, Dev, Kapal, 2023. Smart navigation and energy management framework for autonomous electric vehicles in complex environments. *IEEE Internet Things J.* 10 (21), 18641–18650.
- Salari, Ali Hosseini, Mirzaeinejad, Hossein, Mahani, Majid Fooladi, 2023. A new control algorithm of regenerative braking management for energy efficiency and safety enhancement of electric vehicles. *Energy Convers. Manage.* 276, 116564.
- Shin, MyungJae, Choi, Dae-Hyun, Kim, Joongheon, 2019. Cooperative management for PV/ESS-enabled electric vehicle charging stations: A multiagent deep reinforcement learning approach. *IEEE Trans. Ind. Inform.* 16 (5), 3493–3503.
- Sotoudeh, Seyede Mahsa, HomChaudhuri, Baisravan, 2023. A deep learning-based approach to eco-driving based energy management of hybrid electric vehicles. *IEEE Trans. Transp. Electrification.*
- Suhail, Mohammad, Akhtar, Iram, Kirmani, Sheeraz, Jameel, Mohammed, 2021. Development of progressive fuzzy logic and ANFIS control for energy management of plug-in hybrid electric vehicle. *IEEE Access* 9, 62219–62231.
- Tang, Xiaolin, Chen, Jiabin, Liu, Teng, Qin, Yechen, Cao, Dongpu, 2021. Distributed deep reinforcement learning-based energy and emission management strategy for hybrid electric vehicles. *IEEE Trans. Veh. Technol.* 70 (10), 9922–9934.
- Tie, Siang Fui, Tan, Chee Wei, 2012. A review of power and energy management strategies in electric vehicles. In: 2012 4th International Conference on Intelligent and Advanced Systems. ICIAS2012, vol. 1, IEEE, pp. 412–417.
- Tie, Siang Fui, Tan, Chee Wei, 2013. A review of energy sources and energy management system in electric vehicles. *Renew. Sustain. Energy Rev.* 20, 82–102.
- Upadhyaya, Ashruti, Mahanta, Chitrallekha, 2023. An overview of battery based electric vehicle technologies with emphasis on energy sources, their configuration topologies and management strategies. *IEEE Trans. Intell. Transp. Syst.*
- Wang, Zexing, He, Hongwen, Peng, Jiankun, Chen, Weiqi, Wu, Changcheng, Fan, Yi, Zhou, Jiakuan, 2023. A comparative study of deep reinforcement learning based energy management strategy for hybrid electric vehicle. *Energy Convers. Manage.* 293, 117442.
- Wang, Yong, Tan, Huachun, Wu, Yuankai, Peng, Jiankun, 2020. Hybrid electric vehicle energy management with computer vision and deep reinforcement learning. *IEEE Trans. Ind. Inform.* 17 (6), 3857–3868.
- Xiao, Yao, Fu, Shengxiang, Choi, Jongwoo, Zheng, Chunhua, 2023. A collaborative energy management strategy based on multi-agent reinforcement learning for fuel cell hybrid electric vehicles. In: 2023 IEEE 98th Vehicular Technology Conference (VTC2023-Fall). IEEE, pp. 1–5.

- Xu, Bin, Hu, Xiaosong, Tang, Xiaolin, Lin, Xianke, Li, Huayi, Rathod, Dhruvang, Filipi, Zoran, 2020. Ensemble reinforcement learning-based supervisory control of hybrid electric vehicle for fuel economy improvement. *IEEE Trans. Transp. Electrification* 6 (2), 717–727.
- Xu, Jingyi, Li, Zirui, Gao, Li, Ma, Junyi, Liu, Qi, Zhao, Yanan, 2022. A comparative study of deep reinforcement learning-based transferable energy management strategies for hybrid electric vehicles. In: 2022 IEEE Intelligent Vehicles Symposium. IV, IEEE, pp. 470–477.
- Yang, Ningkang, Han, Lijin, Liu, Rui, Wei, Zhengchao, Liu, Hui, Xiang, Changle, 2023. Multi-objective intelligent energy management for hybrid electric vehicles based on multi-agent reinforcement learning. *IEEE Trans. Transp. Electrification*.
- Zhang, Cetengfei, Zhou, Quan, Shuai, Bin, Williams, Huw, Li, Yanfei, Hua, Lun, Xu, Hongming, 2022. Dedicated adaptive particle swarm optimization algorithm for digital twin based control optimization of the plug-in hybrid vehicle. *IEEE Trans. Transp. Electrification*.